

# MATE ROV COMPETITION

## RANGER MANUAL



This work is licensed under a [Creative Commons Attribution-NonCommercial-NoDerivatives 4.0 International License](https://creativecommons.org/licenses/by-nc-nd/4.0/). Under this license you may download and share this presentation. Please give credit to the MATE Center and MATE II. You may not use these materials for commercial purposes without written permission from the MATE Center and MATE II. Please click on the Creative Common link above for license details.

[www.marinetech.org](http://www.marinetech.org)

## 2019 MATE ROV COMPETITION:

### *Innovations for Inshore: ROV Operations in Rivers, Lakes, and Dams*

## RANGER CLASS COMPETITION MANUAL

For general competition information, including a description of the different competition classes and eligibility requirements, visit [Team Info](#).

## CONTENTS

OVERVIEW.....	3
THINK OF YOURSELVES AS ENTREPRENEURS.....	3
RANGER CLASS – REGIONAL PARTICIPATION/DEMONSTRATION .....	3
PART 1: PRODUCT DEMONSTRATION.....	4
OVERVIEW.....	4
SCORING OVERVIEW .....	5
TIME.....	6
CONTEXT .....	7
NEED .....	8
REQUEST FOR PROPOSALS (RFP).....	8
SIZE AND WEIGHT RESTRICTIONS .....	18
PRODUCT DEMONSTRATION .....	20
TASK 1: ENSURING PUBLIC SAFETY: DAM INSPECTION AND REPAIR .....	20
TASK 2: MAINTAINING HEALTHY WATERWAYS .....	25
TASK 3: PRESERVING HISTORY .....	32
PRODUCT DEMONSTRATION RESOURCES.....	36
NEW IN 2019!!! PRODUCT DEMONSTRATION RESPONSIBILITIES .....	36
PART 2: PRODUCT DEMONSTRATION PROP BUILDING INSTRUCTIONS & PHOTOS.....	37
PART 3: VEHICLE DESIGN & BUILDING SPECIFICATIONS .....	37

<b>1.0 GENERAL.....</b>	<b>37</b>
<b>2.0 SAFETY.....</b>	<b>37</b>
<b>2.1 Job Site Safety Analysis.....</b>	<b>37</b>
<b>2.2 Safety Pre-Inspection.....</b>	<b>39</b>
<b>2.3 Onsite Safety Inspection .....</b>	<b>42</b>
<b>2.4 Safety inspection protocol .....</b>	<b>42</b>
<b>2.5 Safety Inspection Points.....</b>	<b>43</b>
<b>3.0 SPECIFICATIONS .....</b>	<b>43</b>
<b>3.1 Operational.....</b>	<b>43</b>
<b>3.2 Mechanical/Physical.....</b>	<b>44</b>
<b>3.3 Electrical .....</b>	<b>46</b>
<b>3.4 Onboard Electrical Power .....</b>	<b>52</b>
<b>3.5 Power Shutdown.....</b>	<b>52</b>
<b>3.6 Fluid Power .....</b>	<b>52</b>
<b>3.7 Control Systems.....</b>	<b>55</b>
<b>3.8 Command, Control, &amp; Communications (C3).....</b>	<b>56</b>
<b>3.9 MATE Provided Equipment .....</b>	<b>57</b>
<b>3.10 Laser Safety Rules.....</b>	<b>57</b>
<b>PART 4: COMPETITION RULES.....</b>	<b>58</b>
<b>4.1 GENERAL.....</b>	<b>58</b>
<b>4.2 PROCEDURAL .....</b>	<b>60</b>
<b>4.3 DESIGN &amp; SAFETY CONSIDERATIONS.....</b>	<b>63</b>
<b>PART 5: ENGINEERING &amp; COMMUNICATION .....</b>	<b>64</b>
<b>TIPS FOR EFFECTIVE WRITTEN AND ORAL COMMUNICATION.....</b>	<b>64</b>
<b>5.1 COMPANY SPEC SHEET .....</b>	<b>66</b>
<b>5.2 TECHNICAL DOCUMENTATION.....</b>	<b>67</b>
<b>5.3 ENGINEERING PRESENTATION .....</b>	<b>67</b>
<b>5.4 MARKETING DISPLAY.....</b>	<b>69</b>
<b>5.5 CORPORATE RESPONSIBILITY (formerly Outreach and Inspiration).....</b>	<b>70</b>
<b>PART 6: SUBMISSION GUIDELINES AND KEY DEADLINES .....</b>	<b>71</b>

<b>6.1 Documentation .....</b>	<b>71</b>
<b>6.2 KEY DEADLINES .....</b>	<b>74</b>

## OVERVIEW

### THINK OF YOURSELVES AS ENTREPRENEURS

From the exploration of shipwrecks to the remediation of disturbed underwater habitat and installation of instruments on the seafloor, individuals who possess entrepreneurial skills are in high demand and stand out in the crowd of potential job candidates. What are entrepreneurial skills? They include the ability to understand the breadth of business operations (e.g., finances, research and development, media outreach), work as an integral part of a team, think critically, and apply technical knowledge and skills in new and innovative ways. Individuals who develop a mindset for innovation and collaboration will be well prepared for the global workplace and ready to tackle today – and tomorrow’s – societal challenges.

To help you to better understand and develop these skills, the MATE ROV competition challenges you to think of yourself as an entrepreneur. Your first task is to create a company or organization that specializes in solutions to real-world marine technology problems. Use the following questions as a guide.

- What is your company name?
- Who are its leaders – the CEO (chief executive officer – the leader) and CFO (chief financial officer who oversees the budget and spending)?
- Who manages Government and Regulatory Affairs (i.e. who’s in charge of reviewing the competition rules and making sure that they are understood and followed by everyone)?
- Who is responsible for research and development (R&D)?
- Who is responsible for system(s) engineering? Design integration? Testing? Operations?
- Who is responsible for fund-raising, marketing, and media outreach?
- What other positions might you need? (Depending on your personnel resources, more than one person may fill more than one role.)
- What products and services do you provide?
- Who are your potential clients?

In this case, the MATE ROV Competition and the Eastman Company are your “clients” who recently released a request for proposals. A request for proposals (RFP) is a document that an organization posts to solicit bids from potential companies for a product or service. The specifics of your product design and rules of operation as well as the specifics of your product demonstration are included below.

### RANGER CLASS – REGIONAL PARTICIPATION/DEMONSTRATION

**All companies participating in the RANGER class are required to take part in a regional event.**

Companies that win their regional event advance to compete in the RANGER class at the international

competition. The total number of RANGER winners that advance to the international depends on the total number of individual SCHOOLS or ORGANIZATIONS (not teams) that participate in the regional (not only register, but show up and participate on contest day).

- Regionals must have a minimum number of 5 individual schools/organizations in order to send a team to the international.
- Regionals with fewer than 5 individual schools/organizations can send ONE team to the international provided that:
  - In addition to the product demonstration, the regional has required and scored at least 2 of the 3 Engineering and Communication components.
  - The team that advances has:
    - Passed the safety inspection
    - Achieved a demonstration score of at least 100 points, not including size and weight, safety, or organizational effectiveness
    - Achieved a combined Engineering and Communication score of at least 100 points, not including the company spec sheet or corporate responsibility
    - Successfully passes the RANGER video demonstration administered by the MATE ROV Competition
- Regionals with 5– 10 individual schools/organizations send the top ONE team to the international.
- Regionals with 11 – 20 individual schools/organizations can send the top TWO teams to the international.
- Regionals with 21+ individual schools/organizations can send the top THREE teams to the international.
- The regional hosting the international can send one additional team above their allotment to the international.

Companies will be assigned to the regional that is geographically closest to their location. If companies are located equidistant from two or more regionals, the MATE competition coordinator and the coordinators of those regionals will discuss with the company which regional is most appropriate.

RANGER class companies that are prohibitively far from a regional event should contact [MATE competition coordinators](#) for information about conducting a [video demonstration](#).

NO RANGER class companies will be permitted to participate in the international competition without either 1) winning their regional event or 2) submitting a video demonstration that is then approved by MATE competition officials.

## PART 1: PRODUCT DEMONSTRATION

### OVERVIEW

**RANGER** class companies will take part in ONE product demonstration that consists of three distinct tasks:

**TASK #1: ENSURING PUBLIC SAFETY - DAM INSPECTION AND REPAIR**

**TASK #2: MAINTAINING HEALTHY WATERWAYS**

**TASK #3: PRESERVING HISTORY**

**NOTE:** Regional competitions may not include all 3 tasks of the product demonstration; regional competitions may also give companies more than one attempt at the product demonstration. Contact [your regional coordinator or visit your regional contest's website](#) to determine what will take place at your regional competition. Regardless, the product demonstration score will be added to your [ENGINEERING & COMMUNICATION](#) and [SAFETY](#) scores to determine your total, overall score for the competition.

## SCORING OVERVIEW

The competition consists of product demonstrations, engineering and communication, and safety with the following scoring breakdown:

- **Product demonstrations)**
  - 270 points (max), plus a time bonus
  - Size and weight restrictions
    - 20 points (max)
  - Product demonstration safety and organizational effectiveness
    - 20 points (max)
- **Engineering & Communication**
  - Technical documentation
    - 100 points (max)
  - Engineering presentations
    - 100 points (max)
  - Marketing displays
    - 50 points (max)
  - Company Spec Sheet
    - 20 points (max)
  - Corporate Responsibility
    - 10 points (max)
- **Safety**
  - Initial Safety and Documentation Review
    - 20 points (max)
  - Safety Inspection
    - 30 points (max)
  - Job Safety Analysis (JSAs)
    - 10 points (max)

**TOTAL POINTS = 650**

**NOTE: Regional contests may not require all of the Engineering & Communications components or offer the opportunity to earn points for Corporate Responsibility. Contact [your regional coordinator](#) or [visit your regional contest's website](#) for more information.**

## **TIME**

Each product demonstration includes:

- 5 minutes to set up at the product demonstration station
- 15 minutes to attempt the tasks
- 5 minutes to break down and exit the product demonstration station

Your company will have 5 minutes to set up your system, 15 minutes to complete the tasks, and 5 minutes to demobilize your equipment and exit the product demonstration station. During the 5-minute set-up, you may reassemble your vehicle after the size determination and weigh-in and place it in the water for testing and/or trimming purposes. The 15-minute demonstration period will begin after the full 5 minutes of set up time expires, regardless of whether the company is ready to start the product demonstration. It may begin sooner if your CEO notifies the product demonstration station judges that your company is ready to begin.

At any time during the demonstration, you may pilot your ROV to the surface and remove the vehicle from the water for such things as buoyancy adjustments, payload changes, and troubleshooting, but the 15-minute product demonstration clock will stop if a judge determines it is necessary for reasons beyond your control. Otherwise, the clock will only stop after all of the tasks are successfully completed, the ROV has returned to the surface under its own power so that it touches the side of the pool, and a company member at the product demonstration station has physically touched the vehicle. Your ROV is not required to return to the surface between tasks.

Your 5-minute demobilization will begin as soon as the 15-minute demonstration time ends, regardless of where your ROV is located (i.e., still at depth, on the surface, etc.).

Regional competitions may alter the set-up, product demonstration time, or demobilization time. Contact [your regional coordinator](#) or [visit your regional contest's website](#) to verify the timing of your product demonstrations.

## **TIME BONUS**

Companies will receive a time bonus for each product demonstration if you:

- 1) successfully complete all the tasks,
- 2) return your ROV to the surface under its own power so that it touches the side of the pool, and
- 3) physically touch your vehicle before the demonstration time ends.

Companies will receive 1 point for every minute and 0.01 point for every second under 15 minutes remaining.

## CONTEXT

Eastern Tennessee, USA, is probably best known for the Great Smoky Mountains (including the national park that bears their name), the cities of Gatlinburg (gateway to the park) and Pigeon Forge (home of Dollywood), and the University of Tennessee (go Volunteers!). Just northeast of these landmarks and attractions lies the city of Kingsport. Less than 5 miles from the Virginia border, Kingsport is home to Bays Mountain Park and Planetarium, the annual summer Fun Fest, and the Exchange Place Living History Farm, where, before it became a plantation and stagecoach horse “exchange” station, Daniel Boone, traveling along the Wilderness Trail, killed a bear and recorded the incident on a beech tree.



*D. Boone killed a bear on this tree 1775.*

In addition to hiking miles of mountain trails with picturesque views, Kingsport residents and visitors can walk, run, or bike along the South Fork Holston River. Like the Exchange Place, the river also has a place in history. On December 13, 1864, the Civil War Battle of Kingsport took place on its banks. Three hundred Confederate soldiers held off a much larger force of 5,500 Union soldiers for two days before surrendering.

Recreational opportunities as well as community events also abound at nearby Boone Lake, a reservoir formed by the impoundment of the South Fork Holston River behind Boone Dam. Swimming, boating, water skiing, and fishing are popular activities on the lake. Each year the Boone Lake Association, one of the oldest environmental groups in the state of Tennessee, organizes the Boone Lake Clean-Up, where the local community helps to rid the lake of trash and debris, including old tires, tree limbs, and lumber.

Boone Dam has also gotten its share of community attention. Owned and operated by the Tennessee Valley Authority (TVA), this hydroelectric dam was built in the early 1950s as part of greater efforts to control flooding in the Tennessee River watershed. In October 2014, a sinkhole was discovered near the base of the embankment, and water and sediment were found seeping from the riverbank below. While sinkholes are not uncommon in Eastern Tennessee, the locations of the sinkhole and the muddy discharge were indicators of potential issues with the safety of the dam. The TVA immediately began an inspection of the dam and continues to work on repairs and remediation to this day, with regular updates on the “Boone Dam Project” going out to the community.

Along with plenty of opportunities to enjoy the outdoors, discover (or rediscover) American history, and become involved in the community, Kingsport can lay claim to the corporate headquarters of a world-renowned Fortune 300 company. Eastman is a global specialty chemical company that produces a broad range of advanced materials, additives and functional products, specialty chemicals, and fibers



that are found in products people use every day. As a world leader in the diverse markets it serves, Eastman is focused on delivering innovative and technology-based solutions while maintaining its commitment to safety and sustainability.

Eastman believes a truly sustainable company is one that creates significantly more value in the world than the resources it uses. Whether it's through developing more efficient products and bringing innovative solutions to customers, collaborating with world-class scientific institutions to help solve significant global challenges, or working with community partners to have a positive impact, Eastman is committed to enhancing the quality of life in a material way.

## NEED

This year, Eastman is collaborating with the MATE ROV Competition and looking to its competitors to assist the company in doing “Good for Good.” Eastman has issued a request for proposals (RFP) for a remotely operated vehicle (ROV) and crew that can operate in the freshwater environments of Boone Lake, Boone Dam, and the South Fork of the Holston River. The specific tasks for the ROV and operators include:

- 1) Ensuring Public Safety – inspecting and making repairs to a hydroelectric dam. Eastman’s stake in the safety and security of Boone Dam extends beyond its company doors to the communities, cities, and state in which it makes its home.
- 2) Maintaining Healthy Waterways – monitoring water quality, determining habitat diversity, and restoring fish habitat. Eastman commissions studies of the South Fork of the Holston River on a regular basis to ensure the health of both the water and the species that live there.
- 3) Preserving History – recovering a Civil War era cannon and marking the location of unexploded cannon shells. Eastman recognizes the rich heritage of the area and the importance of preserving historical artifacts for generations to come.

Before launch and operations, the ROV must complete a series of “product demonstrations” staged at a swimming pool at various regional locations. (Depth requirements vary depending on competition class; see **SPECIFICATIONS** below.) Companies that successfully complete the product demonstrations and deliver exceptional engineering and communication components (e.g. technical documentation, engineering presentations, and marketing displays) will be awarded the contract.

(Visit [www.youtube.com/watch?v=Tn-jUbpFV4A](http://www.youtube.com/watch?v=Tn-jUbpFV4A) for sound advice from MATE judge Marty Klein. He references 2015, but his words still hold true for each and every competition season!)

## REQUEST FOR PROPOSALS (RFP)

### 1. General

#### *a. Ensuring Public Safety – Dam Inspection and Repair*

Named for the famous frontiersman Daniel Boone, Boone Dam was built in the early 1950s, part of larger efforts to control flooding in the Tennessee River watershed and tap into the hydroelectric power potential of the South Fork Holston River. Boone Dam is 49 meter high, 467 meters long, and has a

generating capacity of 81,000 kilowatts. The dam and its associated infrastructure were listed on the National Register of Historic Places in 2017.



An aerial photo of Boone Dam, with Boone Lake behind it and its waters spilling into the South Fork Holston River. (Photo credit: <https://tunnelingonline.com/nicholson-treviicos-jv-named-foundation-contractor-for-boone-dam-cutoff-wall/>)

During its construction, the original designers and builders of Boone Dam found highly irregular bedrock known as “karst,” which consists of pinnacles separated by 6 to 9-meter deep crevices. Near the surface of the bedrock and within these pinnacles, in a part of the ground called “epikarst,” they encountered voids and soft muddy soils. To limit water seepage underneath the dam, a deep excavation called a “cutoff trench” was created to remove the voids and soft soils within the rock pinnacles and epikarst. In addition, grout was pumped into the foundation to fill any remaining voids beneath the embankment dam.

While this treatment of the foundation was state of the art in the 1950s, dam safety engineers now recognize the potential for deterioration with this type of construction.

In October of 2014, a sinkhole was discovered near the base of the dam’s embankment. Water and sediment were seen seeping from the riverbank below. While sinkholes are not uncommon in Eastern Tennessee, the location of this sinkhole and the muddy flow pointed to potential safety issues with the dam’s infrastructure.

The TVA sprung into action. The authority assembled its safety engineers and called in a variety of external experts to determine whether the safety of the dam may be compromised. It appeared that the wear and tear of time coupled with the region’s geology had finally taken its toll. The conditions of the embankment were found to be favorable to internal erosion, a process in which voids develop within a dam and/or its foundation because of the action of flowing groundwater. If not addressed, the

flow will continue to undermine the foundation of the dam. This presents a huge concern for public safety.

Because internal erosion is one of the leading causes of dam failures worldwide, TVA staff and external experts implemented a number of measures to reduce the safety risk until they could find the best solutions for repairing the cracks and voids in the dam and its foundation. These measures included lowering the level of Boone Lake, which is behind the dam; installing an automated network of sensors to monitor the dam for pressure and temperature changes every 15 minutes and for movement every 30 minutes; assigning staff to be on site for continuous surveillance; and putting an emergency action plan in place.

The TVA and its external experts are currently evaluating potential solutions. These range from building seepage filters to pumping in additional grout, constructing a composite seepage barrier, building berms to fortify the foundation, and – the extreme – removing the dam and constructing a new one.

In addition to locating and repairing cracks, voids, and other structural issues, the TVA is also conducting routine maintenance. One common issue with dams is damage to their trash racks. A trash rack is a metal structure that prevents debris – things such as tree branches and other vegetation, garbage – from entering the intake of the dam. In the course of doing their job, racks can become clogged with debris, so much so that the rack becomes damaged. While in some cases the rack can be repaired, in most others it must be removed and replaced.

\*\*\*\*\*

Eastman has a vested interest in the inspection and repair of the dam infrastructure because of the proximity of the dam to Eastman's corporate headquarters. But its concern goes beyond its company doors to the local communities, cities, and towns where its employees make their homes, raise families, and enjoy the state's natural beauty. For Eastman, it's about providing a safe and secure working *and* living environment.

#### *b. Maintaining Healthy Waterways*

Since the 1960s, Eastman has commissioned world-renowned science institutions to study the rivers upstream and downstream of its major United States manufacturing sites to ensure that its operations are not negatively impacting the environment. One of the most extensive river studies focuses on the South Fork Holston River, which runs through Eastman's manufacturing site in Kingsport, Tennessee.



A river runs through it – “a river” being the South Fork Holston River and “it” being Eastman’s Kingsport, Tennessee manufacturing site. (Photo credit: <http://www.timesnews.net/News/2015/08/03/Eastman-Environmental-stewardship-is-important-to-us>)

The Philadelphia-based Academy of Natural Sciences of Drexel University, a private, nonprofit institution recognized as a pioneer in the assessment of the health of lakes, rivers, and bays throughout the U.S., performed the seventh study on the South Fork Holston River in July 2010. The study documented the river’s water quality and the abundance and diversity of aquatic plants and animals and compared those results to previous studies.

The study measured water quality parameters, including temperature, dissolved oxygen, pH, phosphorous, and nitrogen, and organic carbon and sampled algae and aquatic plants, macroinvertebrates, such as aquatic insects, crayfish and snails, and fish. In addition to the number of individual species, the study also analyzed overall species diversity as that is another indicator of water quality and environmental health. The study focused on selected zones of the South Fork Holston River as well as zones of the connecting Holston River and branching Horse Creek. The scientists compared the results for each zone to those of the other zones in order to gauge the overall health of the ecosystem. The results of the current studies were also compared to previous studies to understand changes over time.





Examples of the macroinvertebrates (crayfish) and fish (rainbow trout) scientists found in the South Fork Holston River. (Photo credits: <https://researchingrivers.wordpress.com/> and <https://www.southeasternanglers.com/the-rivers/south-holston-river-watauga.html>)

The Academy's findings have illustrated improvements in the South Fork Holston River over time. Its reports show major improvement in the numbers and types of aquatic insects, macroinvertebrates (such as crayfish, snails, and worms), and fish found in the river near Riverfront Park. For example, the 2010 study found 47 species of fish and 39 species of macroinvertebrates in one study location near Riverfront Park, compared to 46 and 34, respectively, in 1997. In addition, water chemistry parameters observed in 2010 continued to show improvement over the levels measured in the initial studies during the 1960s and early 1970s.

\*\*\*\*\*

It's time for another river study. In addition to measurements of water quality and assessment of species diversity in the South Fork Holston River, this year Eastman is investing in the restoration of fish species and habitat in Boone Lake, the reservoir that was created by the construction of Boone Dam. More than 1,500 rubber tires currently reside on the lakebed. While the tires do provide habitat and attract fish and other species, over time the rubber has degraded. The tires are in various states of disintegration and, to maintain water quality as well as the health and safety of the lake's inhabitants, must be removed. The plan is to replace them with concrete reef balls. Once installed on the lakebed, the reef balls will provide additional habitat structure for fish species like the rainbow trout, which is also in the process of being "restored." Local fisheries biologists have been working to restock the lake with rainbow trout, to help increase both species diversity and the enjoyment of fishermen and women. These scientists have been raising trout fry in the lab, and now the fry have grown large enough that they are ready to be released. To better their chances for survival, including protection from avian predators flying overhead, the plan is to transport the trout fry offshore and release them at depth, near the bottom of the lake.

Eastman is committed to environmental stewardship – from monitoring water quality to maintaining healthy habitats and species diversity. These studies are just part of Eastman's efforts to operate sustainably and create more value in the world than the resources it uses. From both a company standpoint and a community perspective, it just makes good business sense.

### *c. Preserving History*

At the outset of the American Civil War, Tennessee was one of the most divided states in the country. It was the last of the Southern states to declare secession from the Union as a substantial portion of the population was against secession. Most of those against secession lived in the eastern part of the state.

East Tennessee's loyalty to the Union came from its terrain and traditions. Because of its soil and rugged geography, the land wasn't suitable for large, sweeping plantation estates. Most of the region's mountain farms were small, and cotton, a driving factor in the Deep South, wasn't a predominant crop. Because they didn't grow cotton, a labor-intensive crop, East Tennessee farmers didn't need or rely on slaves as much as landholders in other parts of the state.

East Tennesseans also had a strong antislavery tradition. Slavery was present but not prominent in comparison to other areas of the South. For example, about one-fourth of African-Americans living in Knoxville during the Civil War were free men or women. The first antislavery newspaper in the country was published in East Tennessee in 1819.

The Confederate attack on Fort Sumter, South Carolina on April 12, 1861 followed by President Abraham Lincoln's call for 75,000 volunteers to put the Southern states back in line and "preserve the Union" was the turning point for Tennessee. The state voted to secede. Angered by the withdrawal from the Union, East Tennesseans met in Greenville and Knoxville, eventually opting to secede from Tennessee and remain in the Union, much like West Virginia did in its split from Virginia. The state legislature, however, denied their petition and sent a 4,000-man force to suppress them. Despite this, during the Civil War many East Tennesseans waged guerrilla warfare against the Southern cause by burning bridges, cutting telegraph wires, and spying.



Image from the Battle of Nashville, which took place December 15-16, 1864. (Photo credit: [https://en.wikipedia.org/wiki/Battle\\_of\\_Nashville#/media/File:Battle\\_of\\_Nashville.jpg](https://en.wikipedia.org/wiki/Battle_of_Nashville#/media/File:Battle_of_Nashville.jpg))

Because of Tennessee's strategic location, both the Union and the Confederacy fought fiercely over the state. Indeed, Tennessee's position in the Upper South led President Lincoln to characterize the state as "the keystone of the Southern arch." The state linked the Eastern Theater of the war with the Mississippi River and early became a natural offensive target for the Federal armies. Both sides sought to control Tennessee's rich resources, especially the state's rail and river routes. In the end, nearly 3,000 military engagements were fought on Tennessee soil; only the state of Virginia saw more armed conflicts during the Civil War.

One of those thousands of military battles took place on December 13, 1864 on the banks of the South Fork Holston River. During the Battle of Kingsport, 300 Confederate soldiers held off a much larger force of 5,500 Union soldiers for two days. Out-numbered, out-flanked, and demoralized by the bitter winter weather, the colonel leading the troops finally surrendered. The Confederates suffered 18 dead, and 84 prisoners of war were sent to a Union prison in nearby Knoxville.

While it was the last state to secede from the Union, Tennessee was the first state to rejoin after ratifying the 14<sup>th</sup> Amendment, which guaranteed citizenship rights to former slaves. Some credit this speedy reentry to Andrew Johnson, a Tennessean who became Abraham Lincoln's Vice President at the end of the war...

\*\*\*\*\*

More than 150 years later, scientists hired by the Eastman Company to study the water quality of the South Fork Holston River discovered more than just a thriving benthic community on its muddy bottom. SCUBA divers conducting a video transect came across the muddied, iron-encrusted barrel of a cannon. Nearby, half-buried in the mud, are what look like shells or shell fragments – either that or some other, undeterminable type of debris.

Divers entered the water near the historical plaque that marks the site as the location where the first shot of the Battle of Kingsport was fired. Eastman scientists believe that the cannon and the shells are likely remains from this battle and are determined to recover the cannon in an effort to preserve the city's history and role in the Civil War. In addition, because the shells may be unexploded ordinance that pose a threat to public safety, Eastman is looking to confirm and mark any shells so that an EOD (explosive ordinance disposal) unit can be brought in to safely remove them.



While not from the Battle of Kingsport, this is an example of a cannon used during the Civil War. (Photo credit: [www.gettysburgmuseumofhistory.com/wp-content/uploads/Artillery-Civil-War-0012.jpg](http://www.gettysburgmuseumofhistory.com/wp-content/uploads/Artillery-Civil-War-0012.jpg))

**THIS IS WHERE YOUR MISSION BEGINS.**

*d. Mission Scope and Purpose*

This and the following sections contain the technical specifications and requirements for ROV services needed to support Eastman. In 2019, ROV services include:

**1) ENSURING PUBLIC SAFETY – DAM INSPECTION AND REPAIR**

- Inspecting the foundation of the dam
- Inserting grout into the voids underneath the dam
- Inspecting and repairing a trash rack
- Deploying a secondary micro-ROV to inspect a drain pipe for possible dam failure

**2) MAINTAINING HEALTHY WATERWAYS**

- Measuring the water temperature
- Collecting a water sample and measuring pH and phosphate levels
- Determining habitat diversity by examining benthic species underneath a rock
- Recording collected data on a data sheet
- Transporting and releasing trout fry
- Removing a degraded rubber tire
- Installing a new fish/reef ball

**3) PRESERVING HISTORY**

- Determining the lift capability of the ROV
- Measuring the cannon and calculating the volume of the cannon



- Finding the cannon's casting mark to determine its composition
- Determining if the ROV has enough force to lift the cannon
- Lifting the cannon to the surface, side of the pool
- Identifying and marking the location of cannon shells on the bottom

## 2. Specifications

See the specific tasks described below as well as the **VEHICLE DESIGN & BUILDING SPECIFICATIONS** and **PART 4: COMPETITION RULES** sections.

## 3. Maintenance and Technical Support

The company shall warrant the ROV and associated systems and equipment for at least the duration of the product demonstrations. Repair or replacement shall be at the company's expense, including the cost of shipping the ROV to and from the competition facility.

During regional events, the company shall provide at least one day of technical support to resolve hardware, software, and operational issues. They shall provide at least three days of the same for the international event.

## 4. Shipping and Storage

Refer to [Shipping Information](#) for specifics on shipping to the international competition site.

Delivery of the ROV and associated systems and equipment shall be no later than the date of the geographically closest regional contest or by June 20, 2019, which is the start date of the international competition.

## 5. Evaluation Criteria

- Technical documentation
- Engineering presentation
- Marketing display
- Company spec sheet
- Product demonstration
- Safety

## 6. References

### a. *KINGSPORT*

- <https://youtu.be/eGp3-k0Eccw>
- [www.exchangeplace.info](http://www.exchangeplace.info)
- <http://danielboonetrail.com/>
- [www.eastman.com](http://www.eastman.com)

- [www.eastman.com/Company/Sustainability/Pages/Introduction.aspx](http://www.eastman.com/Company/Sustainability/Pages/Introduction.aspx)
  
- b. ENSURING PUBLIC SAFETY – DAM INSPECTION AND REPAIR**
  - [https://en.wikipedia.org/wiki/Boone\\_Dam](https://en.wikipedia.org/wiki/Boone_Dam)
  - [www.tva.com/Newsroom/Boone-Dam-Project](http://www.tva.com/Newsroom/Boone-Dam-Project)
  - [www.youtube.com/watch?v=Fu8cJT-nEmc](http://www.youtube.com/watch?v=Fu8cJT-nEmc)
  - [www.deeptrekker.com/clearing-trash-racks](http://www.deeptrekker.com/clearing-trash-racks)
  - <https://epd.georgia.gov/safe-dams-program-faq-owner-inspections>
  
- c. MAINTAINING HEALTHY WATERWAYS**
  - [www.eastman.com/Company/Sustainability/features/Environment/Pages/River\\_Studies.aspx](http://www.eastman.com/Company/Sustainability/features/Environment/Pages/River_Studies.aspx)
  - <https://boonelakeassociation.org>
  - [www.youtube.com/watch?v=AIQXPPJFbDI](http://www.youtube.com/watch?v=AIQXPPJFbDI), [www.youtube.com/watch?v=10rAjQT7uMM](http://www.youtube.com/watch?v=10rAjQT7uMM)
  - [www.timesnews.net/News/2015/08/03/Eastman-Environmental-stewardship-is-important-to-us](http://www.timesnews.net/News/2015/08/03/Eastman-Environmental-stewardship-is-important-to-us)
  - [www.eastman.com/Literature\\_Center/P/P237.pdf](http://www.eastman.com/Literature_Center/P/P237.pdf)
  - [www.timesnews.net/Local/2016/02/03/Raw-sewage-flows-into-Bluff-City-family-s-yard-possibly-Boone-Lake](http://www.timesnews.net/Local/2016/02/03/Raw-sewage-flows-into-Bluff-City-family-s-yard-possibly-Boone-Lake)
  
- d. PRESERVING HISTORY**
  - [https://en.wikipedia.org/wiki/Tennessee\\_in\\_the\\_American\\_Civil\\_War#Battles\\_in\\_Tennessee](https://en.wikipedia.org/wiki/Tennessee_in_the_American_Civil_War#Battles_in_Tennessee)
  - <https://www.quora.com/What-side-was-Tennessee-on-in-the-Civil-War>
  - <https://www.knoxnews.com/story/news/2017/08/26/east-tennessee-civil-war-pro-union-divided/599123001/>
  - [http://www.tncivilwar.org/research\\_resources/battles\\_leaders](http://www.tncivilwar.org/research_resources/battles_leaders)
  - [http://www.tn4me.org/minor\\_cat.cfm/minor\\_id/1/major\\_id/5/era\\_id/5](http://www.tn4me.org/minor_cat.cfm/minor_id/1/major_id/5/era_id/5)
  - [https://en.wikipedia.org/wiki/Field\\_artillery\\_in\\_the\\_American\\_Civil\\_War](https://en.wikipedia.org/wiki/Field_artillery_in_the_American_Civil_War)
  - [www.civilwarartillery.com](http://www.civilwarartillery.com)
  - <http://www.civilwarartillery.com/manufacturers.htm>
  - [www.waymarking.com/waymarks/WMKWW2\\_Civil\\_War\\_Battle\\_of\\_Kingsport\\_Tennessee](http://www.waymarking.com/waymarks/WMKWW2_Civil_War_Battle_of_Kingsport_Tennessee)

**IMPORTANT NOTE: Questions about production demonstrations and design and building specifications must be posted to the competition FAQs board located at [www.marinetech.org/forums/](http://www.marinetech.org/forums/). This allows all companies to see the questions and answers and helps to avoid duplicate questions. That said, please make sure that your question(s) has not already been asked – and answered – before posting. It is up to the companies to read, comprehend, and comply with ALL rulings posted on the FAQ board.**

## SIZE AND WEIGHT RESTRICTIONS

In light of some of the environments in which the ROVs will be operating, the Eastman Company has included an ROV size and weight requirement in the request for proposals (RFP). Smaller, lighter vehicles will be given special consideration and vehicles above a certain size and weight will not be considered.

All size and weight measurements will include the vehicle (including the micro-ROV of Task 1), all tools and components, and the tether. The following will NOT be included in the length or weight measurement:

- The topside control system and 1 meter of tether going into the control system
- RANGER class cannon lift mechanisms (if removable from the ROV)

Vehicles will be measured and weighed in the on-deck circle 15 to 20 minutes prior to the company's product demonstration run. Note that the vehicle will be measured and weighed before each product demonstration run. The size and weight bonus, if any, will be added to each product demonstration score.

### **2019 size and weight parameters**

Size measurements will be made using the two largest dimensions of the ROV. Three rings with diameters of 60 cm, 75 cm, and 85 cm will be located on a table in the on deck circle. Companies will place their vehicles on the table and, when ready, ask a MATE ROV Competition official to make the size measurement. The vehicle measurement must include the vehicle and all manipulators/tools that will be used in the product demonstration as well as the vehicle's tether. Any removable lift bags constructed by the company will not be included in size and weight. In addition, the control system and 1 meter of tether may be outside of the measurement circle.

Hand powered lifts and levers and tether management systems may be used with the vehicle. Hand powered lifts and levers will not be included in the size or weight of the ROV. Tether management systems that can be separated from the vehicle will also not be included in the size or weight of the ROV.

Companies may detach manipulator arms and other equipment and place that equipment, next to, on top of, or inside the vehicle frame, but all of the equipment that will be used in the product demonstration must be present and fit within the measurement circle. For example, a company may remove a manipulator arm that extends 20 cm in front of the vehicle and place it on top of the vehicle. The measurement will be made with the arm on top of the vehicle, provided that the length and width are still the largest diameters.

The size rings will be placed over the two largest dimensions of the ROV.

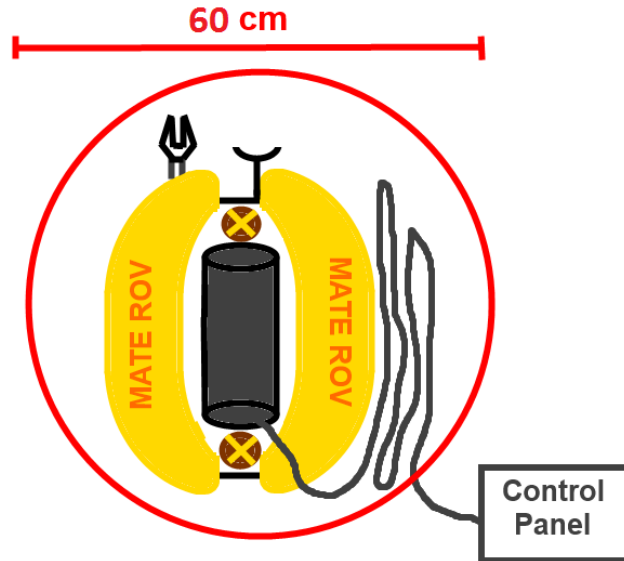

*A RANGER class vehicle, with tools attached and tether coiled beside the ROV, inside the 60 cm diameter ring. This vehicle would earn the company +10 bonus points on the product demonstration score.*

Weight measurements will be conducted using a digital scale. In addition, companies must be able to personally transport the vehicle and associated equipment to the product demonstration station and to the product presentation room. ROV systems must be capable of being safely hand launched.

Competition officials will use the following chart to award points for size and weight:

Size		Weight (in air)	
< 60 cm diameter	+10 points	< 15 kg	+10 points
60.1 cm to 75 cm	+5 points	15.01 kg to 20 kg	+5 points
75.1 cm to 85 cm	+0 points	20.01 kg to 25 kg	+0 points

Vehicles above 85 cm in diameter, or greater than 25 kg in weight, will not be allowed to compete in the product demonstration.

### Size and Weight Protocol

Only the six designated product demonstration company members will be allowed into the on-deck circle during and after the measurement and weigh in. Once a company's vehicle has been measured and weighed, it must remain there until the company moves to its product demonstration station. Companies that detach equipment from the vehicle may not re-install that equipment until the 5-minute set up period. At that time, companies may replace any items that were detached for the measurement, but no new equipment (i.e., equipment that was not included in the size and weight measurements) may be added to the vehicle. If it is discovered that a company added equipment that was not included in the measurements, the company will not be permitted to compete in that product demonstration run.

Videos showing simulated size and weight measurements are posted [here](#).

## PRODUCT DEMONSTRATION

### TASK 1: ENSURING PUBLIC SAFETY: DAM INSPECTION AND REPAIR

This task involves the following steps:

- **Inspecting the foundation of the dam**
  - Following a transect line– 5 points
  - Identifying and counting the number of cracks – 5 points
  - Gathering information about the size of the cracks
    - Determining the length of the longest crack
      - Within 1.0 cm – 10 points
      - Within 2.0 cm – 5 points
      - Not within 2.0 cm – 0 points
  - Mapping the location of the cracks – 5 points
- **Inserting grout into voids underneath the dam – 10 points**
- **Inspecting and repairing a trash rack**
  - Removing the damaged screen of the trash rack – 10 points
  - Installing a new screen – 10 points
- **Deploying a secondary, micro-ROV from the primary ROV to inspect the inside of the drain pipe for indicators of possible dam failure**
  - Identifying areas of muddy water flow inside the pipe using:
    - Micro-ROV only connected to primary ROV by fiber optic cabling – 30 points
    - Micro-ROV connected to primary ROV by copper wiring – 20 points
  - Docking the micro-ROV to the primary ROV – 5 points

**Total points = 90 points**

#### **Product Demonstration Notes:**

Companies may complete the steps of Task 1: Ensuring Public Safety – Dam Inspection and Repair in any order.

Companies must inspect the foundation of the dam. The foundation of the dam will be simulated by a large (up to 1.25 meter by 1.25 meter) corrugated plastic sheet. A grid drawn on the corrugated sheet will divide the area into 16 sections. The corrugated plastic sheet will be suspended in the water column at a distance of 1.25 meters +/- 0.25 meters from the pool wall. The marked side of the corrugated plastic sheet will face the nearby pool wall.

A red line will transect all sixteen squares. A red square on one end of the red line and a red circle on the other end of the red line will mark the starting and ending points. The station judge will inform the company which shape is the starting point and which is the ending point. Companies must maneuver

their vehicle between the plastic sheet and the pool wall, and follow the red transect line to conduct a visual inspection of the foundation of the dam. Companies will either move from the red square to the red circle, or from the red circle to the red square. Companies that successfully follow the red transect line and inspect the foundation of the dam will receive 5 points. Successfully inspecting the dam is defined as following the red transect line from the starting point to the ending point and displaying the complete area of each of the sixteen squares on a video screen.

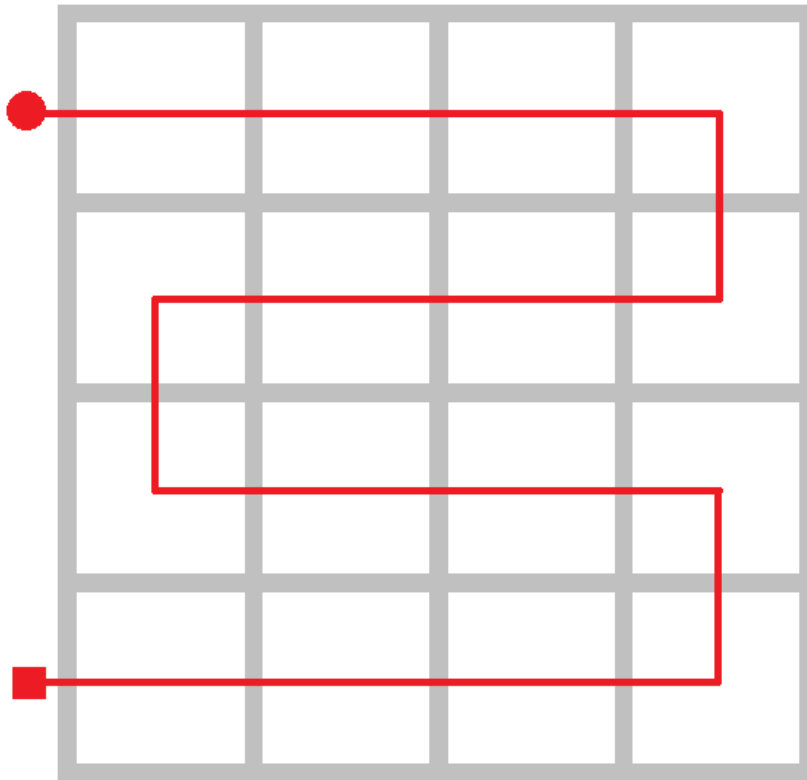

*Diagram of the foundation of the dam with grid depicting sixteen sections and red transect line.*

While following the transect line, the vehicle MUST be close enough to the dam that only one red line is visible in the video screen; other sections of the red line (above or below) must not be visible.

Companies must identify and count the number of cracks on the foundation of the dam. Cracks will be simulated by a line at least 1 cm in width. Companies must examine the entire area of the foundation of the dam and count the number of cracks. Companies will receive 5 points when they successfully identify the number of cracks on the foundation of the dam. Successfully identifying the number of cracks is defined as showing the station judge each crack on a video display and informing the judge of the total number of cracks. Companies may not guess at the number of cracks.

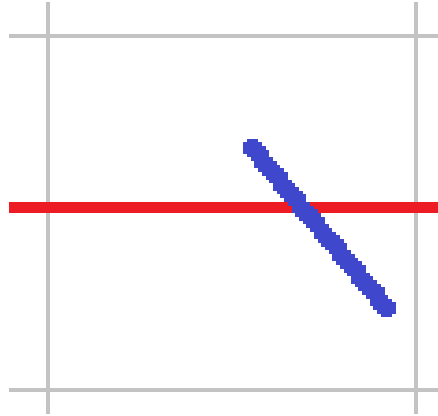

*Diagram of a crack in the foundation of the dam.*

Companies must determine the length of the longest crack on the foundation of the dam. One crack will be between 12 cm and 35 cm in length. All of the other cracks will be less than 12 cm in length. Companies should measure the length of the crack that is between 12 cm and 35 cm in length. Companies must show the judge their length measurement; companies may not guess at the length of the crack. Companies that successfully measure the length of the crack, within 1.0 cm of the true length, will receive 10 points. Companies that measure the length of the crack between 1.1 cm and 2.0 cm of the true length, will receive 5 points. The product demonstration judge must be able to see or evaluate the measurement taken by the company. No guessing is permitted.

During or after identifying all of the cracks on the foundation of the dam, companies must map their location. A blank grid map will be provided to companies at the product demonstration station. The blank grid map will show the grid defining the sixteen sections and the red transect line. Companies must mark each crack on the grid map. The mark for each crack must be in the proper grid section, and should be located above, below, left or right of the red transect line. The length in cm of the longest crack should also be noted on the map. Companies will receive 5 points for successfully mapping all of the cracks on the grid map. Successfully mapping all the cracks is defined as the proper number of cracks on the grid map, all marks in the proper grid section, and all marks properly located above, below, left of, right of or intersecting the red transect line. No partial points are given. Companies should include the length of the crack that they measured, even if that length was incorrect.

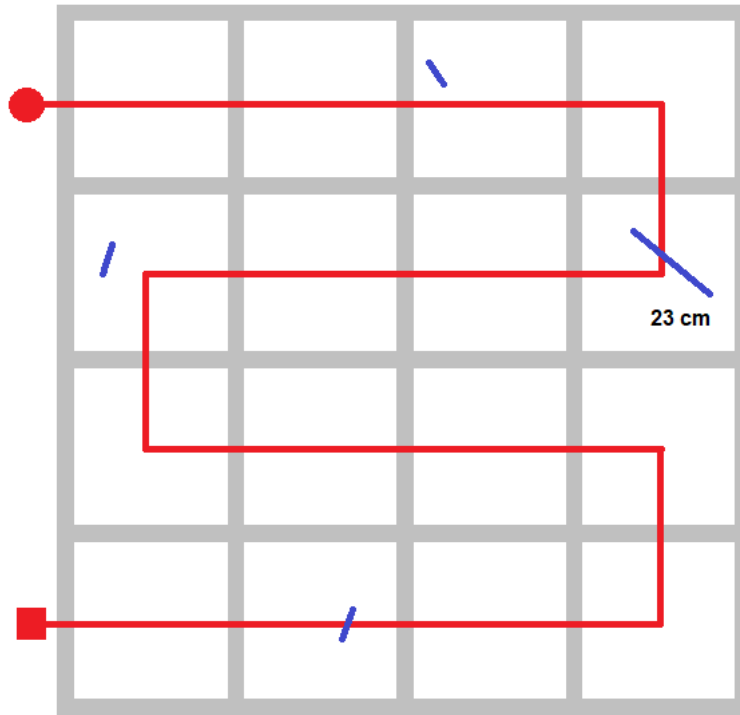

*Grid mapped with four cracks. The four cracks are denoted as above, right and below the red transect line. The length of the longest crack is noted.*

Companies must insert grout into a void underneath the dam. Grout will be simulated by small round stones (Mexican beach pebbles). The void will be simulated by a plastic container. A black line inside the container will mark the minimum fill volume; enough stones must be inserted into the container so that they completely cover this line. A source of stones will be provided on the surface side of the pool. Companies must design a device to carry the stones down to and fill the void. Companies will receive 10 points when they successfully fill the void with grout. Successfully filling the void with grout is defined as the black line inside the container completely covered with stones and no longer visible. Companies must show the station judge through a video camera that this line has been completely covered to receive points.

Companies will need to insert approximately 300 ml worth of grout into the void.

Companies must inspect and repair a trash rack by removing the damaged trash rack screen. The trash rack will be constructed from ½-inch PVC pipe. The damaged screen will also be constructed of ½-inch PVC pipe, with a #310 U-bolt as a grab point for the screen. The bottom of the damaged screen will be inside a cradle and the top of the screen will be placed at an angle against the PVC framework of the trash rack. Companies will receive 10 points when they successfully remove the damaged screen of the trash rack from the pool. Successfully removing the damaged screen is defined as returning the damaged screen to the surface, side of the pool and placing it on the pool deck.

After removing the damaged trash rack screen, companies must install a new screen into the designated area. The new trash rack screen will be constructed of ½-inch PVC pipe, with a #310 U-bolt as a grab



point for the screen. One new screen will be located at the surface, side of the pool and may be attached to the ROV during the set up period. Companies will receive 10 points when they successfully install the new screen onto the trash rack. Successfully installing the new screen is defined as the ROV no longer in contact with the screen, both sides of the bottom edge of the screen inside the PVC cradle of the trash rack, and the top of the screen placed at an angle against the PVC framework at the top of the trash rack. The new screen must stay in place for 10 seconds after being released from the ROV.

The damaged screen will weigh less than 10 Newtons in water.  
The new screen will weigh less than 10 Newtons in water.

Companies will need to remove the damaged screen from the trash rack before installing the new one, but companies may return the damaged screen to the surface side of the pool after installing the new screen.

Companies must build and deploy a secondary ROV from their primary ROV to inspect the inside of a drain pipe for indicators of possible dam failure. The drain pipe will be no longer than 3.1 meters and constructed from [6-inch Corex drain pipe](#). The Corex drain pipe will rest on the bottom of the pool. Over its 3.1 meter length the Corex drain pipe may curve up to 90°. The far end of the pipe will terminate with an end cap.

Companies must use their micro-ROV to inspect the inside of the drain pipe for muddy water flow, which indicates possible dam failure. The muddy water flow will be simulated by 10 cm long strands of brown foam sheeting placed inside the pipe.

Companies will receive points when they successfully identify the area of muddy water flow in the pipe. Successfully identifying the muddy water flow is defined as showing the station judge an image of the brown foam sheeting inside the 6-inch pipe on the company's video display.

Companies whose micro-ROV is attached to the primary ROV only by fiber optic cables will receive 30 points when they successfully identify the area of muddy water. To receive these points, fiber optic cable must be the only connection between the primary ROV and the micro-ROV.

Companies whose micro-ROV is attached to the primary ROV by copper (or other non-fiber optic) wiring will receive 20 points when they successfully identify the area of muddy water.

Companies should be prepared for low light levels inside the Corex drain pipe.

Once the pipe inspection is complete, the micro-ROV must reattach to or dock with the primary ROV. Companies will receive 5 points for successfully docking with their primary ROV. Successfully docking is defined as the micro-ROV attached to or docked with the primary ROV. Also, the micro-ROV tether must be managed and completely contained within the frame of the primary ROV or micro-ROV. No part of the tether may be outside of, or hang below, either ROV. After completing the pipe inspection task, companies must demonstrate to the station judge that the ROV is attached to or docked with the primary ROV and that the tether is properly stowed before moving on to complete other product

demonstration tasks. Companies that do not have a properly stowed micro-ROV or tether may return to the surface to remove the micro-ROV system or repack the micro-ROV or its tether inside the primary ROV. Companies that return to the surface to complete this step will not receive points for docking their micro-ROV within the primary ROV, but may continue on to other tasks.

Once the micro-ROV has successfully docked with the primary ROV (companies have received 5 points for docking), companies may choose to return to the surface and remove the micro-ROV from their primary ROV. Companies will not lose points, or otherwise be penalized, for removing their micro-ROV after completing the pipeline inspection task. Companies may return to the surface and remove their micro-ROV without docking. They will not lose points, or otherwise be penalized but will not receive the 5 points for docking.

NOTE: Companies may not use the micro-ROV to complete other competition tasks or as an additional camera viewpoint away from the primary ROV. Companies will not receive points for completing other tasks if the micro-ROV is in the water and not attached to or docked with the primary ROV.

**Micro-ROV specifications:**

The micro-ROV must be able to move through a 6-inch curving Corex pipe. The minimum bending radius for the pipe will be 152 cm; the pipe may bend 90° over 2.4 meters of length. The micro-ROV, the micro-ROV tether and the tether management system must be included with the primary ROV during size and weight measurements.

The micro-ROV falls under the Non-ROV rules and specifications. See [3.3.1 Non-ROV Device Power Specifications](#) for more information. Below is a summary of the micro-ROV NRD rules.

Micro-ROVs can be powered from the primary ROV or from batteries onboard the device. Micro-ROV power is limited to 12 VDC maximum and 6 amps maximum. If powered from ROV power, the micro-ROV must have a 7.5 amp (or smaller) fuse at the point of connection to ROV power.

If on board power is used, the specifications of ELEC-NRD-004 must be met.

Micro-ROVs are permitted to contain thrusters and cameras.

## **TASK 2: MAINTAINING HEALTHY WATERWAYS**

**This task involves the following steps:**

- **Monitoring water quality**
  - **Measuring the water temperature – up to 10 points**
    - **Temperature measurement is within 2°C of benchmark – 10 points**
    - **Temperature measurement is between 2.01°C and 4°C of benchmark – 5 points**
    - **Temperature measurement is not within 4°C of benchmark – 0 points**
  - **Collecting a water sample from the bottom – 10 points**

- Using a water monitoring kit to
  - Measure the pH of the water sample – 5 points
  - Measure the phosphate levels of a water sample – 5 points
- Determining habitat diversity
  - Lifting a rock from the bottom – 5 points
  - Examining the benthic species underneath the rock
    - Using a handbook to determine the number and type of benthic species – 5 points
    - Using image recognition to determine the number and type of benthic species – 20 points
  - Recording the date, time, temperature, pH, phosphate, and species diversity on a data sheet – 5 points
- Transporting and releasing trout fry – 5 points each, 10 points total
- Restoring fish habitat
  - Removing a degraded rubber tire – 10 points
  - Installing a new fish/reef ball – 10 points

**Total points = 90 points**

**Product Demonstration Notes:**

Companies may complete the steps of Task 2: Maintaining Healthy Waterways in any order.

Companies are required to provide their own sensor to measure the temperature of the water near the water sample collection point. A MATE temperature sensor, used as a benchmark, will be located within a 1-inch PVC coupling. Companies should take their measurement as close to the MATE sensor as possible. Companies must show the station judge their temperature reading display; companies may not guess at the temperature. Companies will receive 10 points if their temperature reading is within 2°C of the MATE benchmark reading. Companies will receive 5 points if their temperature reading is between 2.01°C and 4°C of the MATE benchmark reading.

MATE will provide a calibration testing station at the competition so that companies can compare their temperature reading to a MATE temperature reading.

Companies must collect a water sample from the bottom of the pool and return it to the surface. The water sample will be inside a length of 1-inch PVC pipe with a threaded end cap on one end. One end of the pipe will unscrew to allow access to the sample inside. A length of rope will act as a grab point on the 1-inch pipe. Companies will receive 10 points when they successfully collect the sample. Successful collection is defined as returning the water sample to the surface, side of the pool.

The water sample will weigh less than 5 Newtons in water.

Companies must use a test kit to measure the pH and phosphate levels of the water sample. MATE will supply the test kit for each station; companies do not need to supply their own water quality test kit.

MATE will use the following test kits:

[Jellas Universal pH Test Kit With Paper Strips Roll](#)  
[LaMotte Insta-Test Low Range Phosphate Test Kit](#)

Your regional competition may use a different type of test kit. Your regional coordinator will provide you with the details of the kit.

Companies will open the PVC water sample and pour some of the liquid inside the sample into a test container. Companies will use the pH test kit provided by MATE to measure the pH of the sample liquid. Companies must show the result of their pH test to the station judge; companies may not guess at the pH of the sample. The process for properly using the Jellas pH test kit will be detailed in the prop building instructions and photos document. Companies will receive 5 points when they successfully measure the pH of the water sample. A successful pH measurement is defined as within 1 range increment on the pH scale.



*Left: pH test kit litmus paper. Right: Litmus paper after being dipped into the sample.*

Companies must also measure the phosphate concentration of the liquid sample. Companies will use the phosphate test kit provided by MATE to measure the phosphate concentration. Companies must show the result of their phosphate test to the station judge; companies may not guess at the phosphate concentration of the sample. The process for properly using the Insta-test phosphate test kit will be detailed in the prop building instructions and photos document. Companies will receive 5 points when they successfully measure the phosphate concentration. A successful phosphate measurement is defined as within one range increment, measured in parts per billion (ppb) on the color measurement scale.

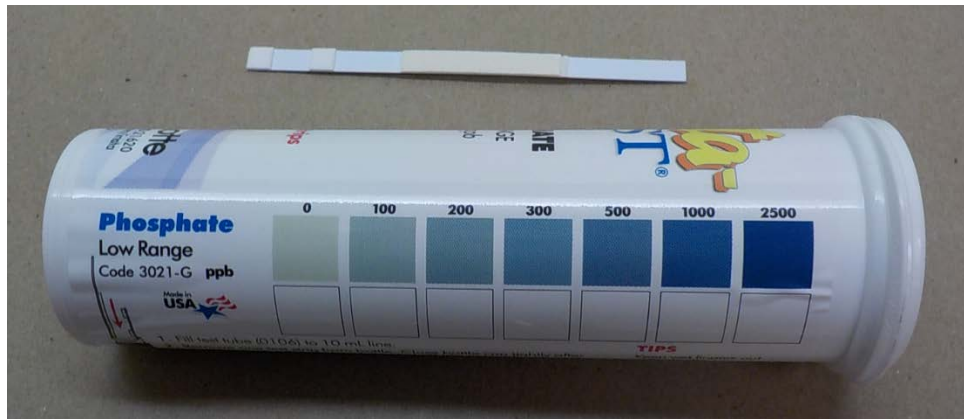

*Insta-test phosphate test kit*

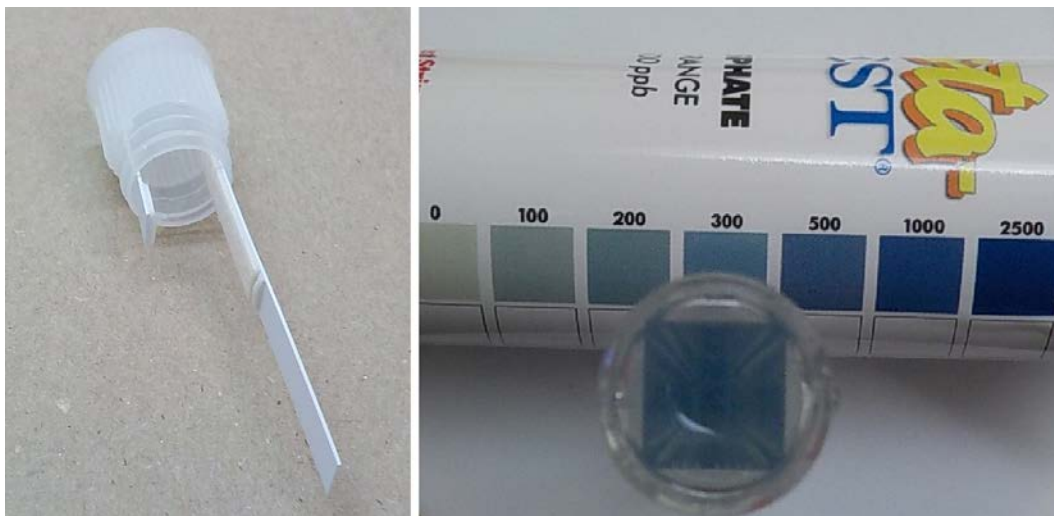

*Left: Preparing the test strip in the cap of the sample bottle.*

*Right: Phosphate concentration of 300 ppb.*

Companies must lift a simulated rock from the bottom of the pool and determine the benthic diversity underneath the rock. The rock will be simulated by a ½-inch PVC framework covered with a corrugated plastic sheet. A section of the ½-inch PVC pipe will act as a handle to use as a grab point. Companies will receive 5 points when they successfully lift the rock from the bottom. Successfully lifting the rock from the bottom is defined as the simulated rock under control of the ROV and no longer in contact with the pool bottom or the contents underneath the rock. Companies may place the simulated rock on the bottom after successfully lifting it.

The simulated rock will weigh less than 5 Newtons in water.

Once the rock is lifted, companies will examine the benthic species underneath the rock. The benthic species will be located on the topside of a corrugated plastic sheet attached to a ½-inch PVC framework that rests on the bottom of the pool. Four different species will be represented by the following shapes: black triangles, squares, lines, or circles painted onto a corrugated plastic sheet attached to ½-inch PVC

pipe. Each shape will be approximately 3 cm in length or diameter. The line will be 3 cm long and 0.5 cm wide. Companies must identify the species by either consulting a handbook or by image recognition software.

Companies may use their video image of the benthic species and the RANGER Benthic Species Handbook to identify and count the number of each species. The handbook is posted on the [competition website](#). During the event, MATE will provide a handbook at each product demonstration for companies to reference; companies do not need to supply their own handbook. Companies must inform the station judge of the different species and how many of each species were found under the simulated rock. For example, based on the figure below, companies would report four of species A to the station judge (species A being a black triangle), one of species B (species B being a black square), one of species C (species C being the black line), and three of species D (species D being a black circle). Companies will receive 5 points when they use their video image and the handbook to successfully identify the species under the rock and report that information to the station judge.

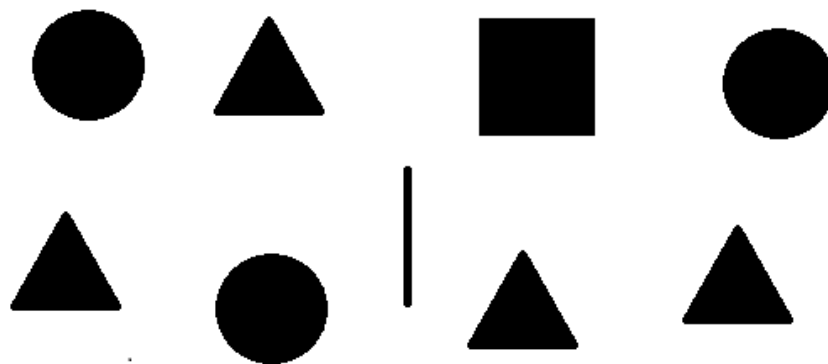

Example of benthic species

Alternatively, companies may develop image recognition software to identify the benthic species. The company's software must determine the number and type of each species found underneath the rock and display the proper number for each symbol on a video screen. Companies will receive 20 points when the proper number and symbol for each species is output to a video screen and shown to the product demonstration judge. The [RANGER Benthic Species Handbook](#) has additional information on the four benthic species.

The output on the video display should be a red number and a red circle, triangle, line, and square. The software must output the proper number and symbol for the product demonstration judge to see. A company member is not allowed to verbally report the species identification.

For example, if two black circles, one black triangle, four black lines, and two black squares are imaged underneath the rock, the output would be:



There will be no more than 6 of any one species underneath the rock, and no more than 15 species total underneath the rock.

Prior to the competition, companies may be required to demonstrate the effectiveness of their image recognition software. Companies are required to submit a data flow diagram of their image recognition software, an algorithm description document detailing the inputs to and outputs from the vision processing, and a library of code files. More information on the submission of image recognition documentation can be found at [DOC-012](#).

At the competition but before the product demonstration, companies are required to demonstrate their image recognition software in a hands-free, “in air” test. Companies will be required to set up their vehicle and prepare their image recognition software. When ready, all company members must move away from the ROV and control board. A judge will then place a sample of benthic species in front of the ROV view. The image recognition software must identify the species without input from any company members. Note: This demonstration will take place in air; companies should design their software to identify benthic species both in air and underwater. Regionals may not require this demonstration. Contact [your regional coordinator or visit your regional contest’s website](#) for the image recognition requirement.

Companies that do not submit their documentation or cannot pass the image recognition demonstration will be required to use the handbook for identification and, as a result, will only receive 5 points if successful.

When companies have measured and reported the water temperature, pH of the water sample, the phosphate concentration of the sample, and the species underneath the rock, they will record that information, along with the date and time, on a data sheet. MATE will provide the data sheet with appropriate rows and columns for the data. MATE will also provide a pen or pencil to record the data. Companies will receive up to 5 points for recording their data. Companies that measured none or one of the four types of data (temperature, pH, phosphate, benthic diversity) will receive 0 points for recording the data. Companies that measured two to four types of data will receive 5 points for recording the data. Companies should also record the date and time of the product demonstration attempt onto the data sheet. Companies should enter, and will get points for recording, the data points they measured or



collected, even if those data points are outside the accepted range for that measurement. For example, if a company measured a temperature of 15.4°C, but the temperature of the water is 23.8°C, companies should still record 15.4°C temperature actually measured. Companies would not receive points for measuring the water within 4°C of the benchmark, but would receive points for recording this data point onto the data sheet.

Companies are required to transport two simulated trout fry (baby trout) and release them into a designated area. The trout fry will be simulated with [rubber fishing lures](#) whose hooks have been removed. The designated area will be constructed from ½-inch PVC pipe and painted green. Two simulated trout fry will be located at the station during the set up period. Companies must design a device to transport the trout fry without damaging or injuring the fish. Companies may not carry trout fry directly in a gripper that applies pressure to the body of the fish. The device must transport the trout fry to the designated location on the bottom then release (remove) the trout fry into the designated area. Companies may place the trout fry into the device during the set period of the product demonstration. Companies will receive 5 points for each trout fry successfully placed in the designated area, 10 points total. Successfully placing a trout fry into the designated area is defined as the rubber fishing lure no longer in contact with the vehicle, resting on the bottom of the pool, and completely within the designated area. If a fish is later displaced from the designated area because of motor prop wash, tether dragging along bottom, etc., companies will not lose points. If a fish exits the device at any time, companies may not attempt to re-capture the fish. If the escaped fish lands in the designated area, companies will receive points for successfully placing the trout fry in the designated area. If the escaped fish does not land in the designated area, the company will not receive points for placing that fish.

The two simulated trout fry (combined) will weigh less than 5 Newtons in water.

Companies must remove a degraded tire and return it to the surface. The degraded tire will be constructed from 3-inch Corex drain pipe. The degraded tire will be located on the bottom of the pool. Companies will receive 10 points when the degraded tire is removed from the water and placed on the pool deck.

The degraded tire will weigh less than 10 Newtons in water.

Companies must install a new reef/fish ball into a designated area. The reef/fish ball will be constructed from ½-inch PVC pipe. A #310 U-bolt will act as a grab point on the fish/reef ball. The designated area will be constructed from ½-inch PVC pipe and painted orange. The designated area used for installing the reef/fish ball will be located adjacent to the trout fry designated area. The reef/fish ball will be available on the surface, side of the pool. The reef/fish ball can be attached to the ROV during the set up time. Companies will receive 10 points for successfully installing the reef/fish ball into the designated area. Successfully installing the reef/fish ball is defined as the PVC frame of the ball no longer in contact with the ROV, resting on the pool bottom, and at least one corner on or over the PVC of the designated area. If the reef/fish ball is later displaced from the designated area because motor prop wash, tether dragging along bottom, etc., companies will not lose points.



### TASK 3: PRESERVING HISTORY

This task involves the following steps:

- **Recovering the Civil War era cannon**
  - **Prior to the competition:**
    - **Determining the lift capability of your ROV – 5 points**
  - **At the competition:**
    - **Calculating the amount of force needed to lift the cannon**
      - **Calculate the volume of the cannon – up to 30 points**
        - **Length measurement**
          - **within 1 cm – 5 points**
          - **not within 1 cm – 0 points**
        - **Radius 1 measurement**
          - **Within 0.5 cm – 5 points**
          - **Not within 0.5 cm – 0 points**
        - **Radius 2 measurement**
          - **Within 0.5 cm – 5 points**
          - **Not within 0.5 cm – 0 points**
        - **Radius 3 measurement**
          - **Within 0.5 cm – 5 points**
          - **Not within 0.5 cm – 0 points**
        - **Calculation within 10 cm<sup>3</sup> of actual – 10 points**
      - **Determining the composition (specific gravity) of the cannon**
        - **Using the cannon's casting mark to identify the build location and build date and consulting a handbook to determine the composition – 5 points**
      - **Calculating the weight of the cannon in water– 5 points**
      - **Determining if the ROV has enough thrust to lift the cannon – 5 points**
    - **Returning the cannon to the surface, side of the pool – 20 points**
- **Identifying and marking the location of metal cannon shells/non-metal debris – 5 points each, 20 points total**

**Total points = 90**

#### **Product Demonstration Notes:**

Companies may choose to recover the cannon or mark the location of cannon shells first. Companies must calculate the amount of force needed to lift the cannon before returning the cannon to the surface, side of the pool. Companies that do not successfully calculate the necessary lift force can still recover the cannon.

Prior to the competition, companies must determine the lift capability of their ROV. Companies must test their ROV and determine the amount of upward force that it generates. Companies should include

all lift factors incorporated into their ROV, including thrusters, variable buoyancy systems, etc. Lift mechanisms not directly incorporated into the ROV (independent lift bags, etc.) should not be included in the determination. Companies may want to test motor thrust at variable voltages (see ELEC-002R) to provide multiple lift capability values. Companies using vectored vertical thrusters must calculate for the vector angles. Companies should compile a document detailing their lift capability, in Newtons, and include descriptions of any tests performed. This document is limited to one-page, single-sided. Companies will receive 5 points when they provide their lift capability document to the station judge.

At the competition, companies must calculate the amount of force needed to lift the cannon. Companies will need the volume of the cannon and the composition of the cannon to calculate the force needed to lift the cannon in water. The volume will be calculated by measuring the dimensions of the cannon in the pool. The composition of the cannon will be determined by finding the casting mark to determine the build date and location and consulting a handbook to determine the composition.

The cannon will be constructed from PVC or ABS pipe and connectors of different diameters. Companies must measure the overall length of the cannon, the outer diameter of both ends of the cannon, and the bore diameter of the cannon. NOTE: Although the cannon will be constructed from various lengths of pipe, companies should assume the outside of the cannon is a section of a cone and the bore of the cannon is a cylinder that extends the entire length of the cannon.

Companies must measure:

- Overall length of the cannon (L)
- Outer radius of end 1 of cannon (R1)
- Outer radius of end 2 of cannon (R3)
- Bore radius (R2)

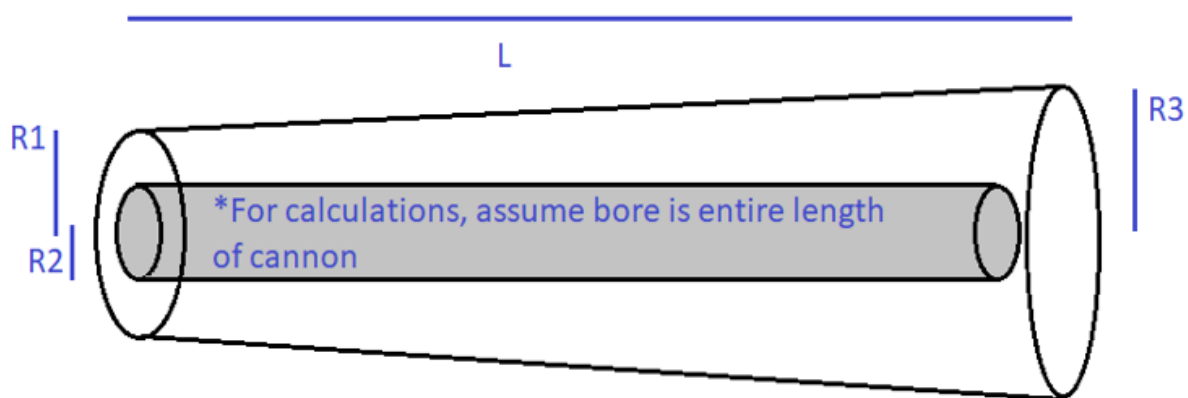

Companies must show each measurement to the station judge, they may not guess. Companies will receive the following points for each of the four measurements:

	Within 1 cm	Within 0.5 cm	Incorrect measurement
Cannon length	5 points	-	0 points
Radius 1	-	5 points	0 points
Radius 2	-	5 points	0 points
Radius 3	-	5 points	0 points

Companies only get one chance to correctly measure the lengths.

Once the company has made all four measurements, the station judge will provide the company with the exact dimensions (to one decimal place) of the cannon in centimeters. Exact measurements will be provided to assist companies in being successful in their calculations of the volume of the cannon. Small errors in measurements could lead to large differences in overall volume. Companies will use the provided dimensions to calculate the volume of the cannon. Companies will receive 10 points when they successfully calculate the volume of the cannon. Successfully calculating the volume is defined as the calculated volume within 10 cm<sup>3</sup> of the actual value. Companies should show their calculations, or the program used to calculate the volume, to the station judge; companies may not guess at the volume.

For example, if the overall length (L) is 46 cm, radius 1 (R1) is 5.3 cm, radius 2 (R2) is 2.8 cm, and radius 3 (R3) is 7.7 cm, then the overall volume would be 5042.07 cm<sup>3</sup>.

For calculation purposes, companies can assume the bore length is equal to the cannon length.

A casting mark will be printed on one side of the cannon. The casting mark will contain a series of letters and numbers, printed in 2-inch black on white letters. Using the casting mark, companies will consult the Cannon Handbook to determine the foundry where the cannon was constructed, the date of the cannon's construction, and the composition of the cannon. The handbook will also include the specific gravity of the cannon composition. This handbook is posted on the [competition website](#). Companies will receive 5 points when they successfully determine the composition of the cannon. Successfully determining the composition of the cannon is defined as showing the station judge the section in the handbook with the composition matching the date and foundry of the cannon.

Using the cannon volume and the composition, companies will calculate the weight of the cannon in water, which is also the amount of force (in Newtons) needed to lift the cannon from the bottom. Companies will receive 5 points when they successfully calculate the force needed to lift the cannon. Successfully calculating the force is defined as showing the station judge your calculations, and the force needed being within 5 Newtons of the actual force needed to lift the cannon.

Hint: Remember Archimedes' principle when calculating the lift force needed for an object in water.

Once a company has successfully calculated the amount of force needed to lift the cannon, the judge will present them with the actual weight in water of the PVC pipe cannon and the force needed to lift it.

Companies will compare the force needed to lift the PVC cannon to the lift force capability of their ROV. Companies must report to the station judge either the amount of excess lift capability, in Newtons, their ROV has compared to the force needed to lift the cannon or the amount of additional lift needed, in Newtons, to bring the cannon to the surface. Companies will receive 5 points when they successfully compare the two forces and report the excess or additional lift, in Newtons, to the station judge. Successfully comparing the two forces is defined as informing the station judge the difference (in Newtons to 1 significant digit) between the lift capability of their ROV and the force needed to lift the cannon. Note: Companies that tested their lift capacity at various voltages should choose the test voltage closest to the MATE supply voltage for their calculation.

Example: Company A has determined that their ROV lift capability is 12.7 Newtons. 22.3 Newtons are needed to lift the PVC cannon. Companies would report to the station judge that they need an additional 9.6 Newtons of lift capability to bring the cannon to the surface. Company B has determined that their ROV lift capability is 30.3 Newtons at 13.0 volts and 34.1 Newtons at 14.0 volts. The MATE power supply is providing 14.1 volts, so the company chooses to use the vehicle thrust calculated at 14.0 volts. Company B would report their ROV has an excess of 11.8 Newtons of thrust and can lift the cannon without additional devices.

Companies that did not successfully calculate the amount of force needed to lift the cannon will not receive points for comparing that force to the lift capability of their ROV.

Companies must return the cannon to the surface side of the pool. The cannon will have a #310 U-bolt that will act as a grab point. Companies may return the cannon to the surface, side of the pool by any means they wish, with the exception of lifting and recovering the cannon manually. No team member can physically lift or pull the cannon to the surface. Additional devices may be used to lift the cannon to the surface. MATE will not provide any devices; companies must design and bring their own devices. Companies will receive 20 points when they successfully return the cannon to the surface, side of the pool. Successfully returning the cannon is defined as the cannon under control of the ROV and the ROV at the surface, side of the pool. Company members may reach in with a hand to remove the cannon from the ROV and place it on the pool deck.

The cannon will weigh less than 50 Newtons in water.

Note: Once your company begins operations to bring the cannon to the surface, you may no longer perform any force calculations.

Companies must examine four objects that may be unexploded cannon shells. The objects will be simulated by lengths of  $\frac{3}{4}$ -inch PVC or metal pipe. Each pipe will be completely wrapped in black plastic tape, making the two different types of pipe visually indistinguishable from each other. Each length of pipe will be attached to a non-ferrous weight and placed in a grid on the bottom of the pool. The grid will be constructed from  $\frac{1}{2}$ -inch PVC pipe. Companies must design and create a sensor that can distinguish the metal pipes (metal cannon shells) from the PVC pipes (non-metal debris). Companies

should explain to the station judge how they are identifying metal versus non-metal objects and show the station judge each object identified. Companies may not guess.

Once an object is identified as metal or non-metal, companies must place a colored marker near each object. Markers will be constructed from ½-inch PVC tees painted red or black. Multiple red and black tees will be available at each product demonstration station. Red tees will be used to mark objects identified as metal, black tees will be used to mark objects identified as non-metal. Companies will receive 5 points for each object successfully identified and marked, 20 points total. Successfully identifying an object is defined as showing the station judge the sensor determining the identity of the object. Successfully marking an object is defined as the proper colored tee placed in the grid square containing the object, and no other colored tee in that square. If a wrong colored tee is inadvertently dropped into the square, companies must remove it to receive points.

#### **Time bonus:**

If a company has successfully completed all product demonstration tasks and is returning to the surface with the old trash rack screen, degraded tires, and/or cannon, the product demonstration time will stop when a member of the company touches the vehicle. The trash rack screen, degraded tires, or cannon onboard may be detached and set on the pool deck after the clock has stopped. If any of these items is subsequently dropped from the vehicle and sink to the bottom, the company will not receive points for returning the item to the surface, time will not restart, and the company will not receive a time bonus.

#### **PRODUCT DEMONSTRATION RESOURCES**

An example of a [blank grid map](#) for mapping cracks on the foundation of the dam.

The [RANGER Benthic Species Handbook](#) contains identification information for various benthic species found in Tennessee lakes and rivers.

An example of the [Maintaining Healthy Waterways RANGER Data Sheet](#). MATE will provide a data sheet at each station for RANGER companies.

The [RANGER Cannon Handbook](#) contains 19<sup>th</sup> century cannon foundries, the casting marks the foundries used, and the composition of cannons built at the foundry for various years.

#### **NEW IN 2019!!! PRODUCT DEMONSTRATION RESPONSIBILITIES**

Companies are responsible for providing their own micro-ROV, temperature sensor, and lift device for the cannon. Companies must also design and bring any tools or devices to carry and deliver the other MATE product demonstration props.

The MATE ROV Competition will provide all of the remaining product demonstration items, including the water quality test kits.

## PART 2: PRODUCT DEMONSTRATION PROP BUILDING INSTRUCTIONS & PHOTOS

The product demonstration prop building instructions and photos have been made their own, separate document. This document will be released with, but separate from, this competition manual.

## PART 3: VEHICLE DESIGN & BUILDING SPECIFICATIONS

### 1.0 GENERAL

Questions about vehicle design and building specifications, as well as competition rules, should be posted to Competition Help within the MATE Forum Hub ([www.marinetech.org/forums/](http://www.marinetech.org/forums/)). This ensures that all companies can view the questions and answers and helps to avoid duplicate questions. That said, companies should make sure that their questions have not already been asked – and answered – before posting. When posting their question, companies should reference the specific specification (e.g. ELEC-002R).

Conventions: All values contained in this document are threshold values unless specifically stated otherwise. All water depths are given in meters (m). All dimensions and measurements utilize SI units.

[Your regional coordinator or your regional contest's website](#), will inform you of any specific requirements or changes for your regional.

### 2.0 SAFETY

Safety is the competition's primary concern and guiding principle. Any system that is deemed unsafe by competition officials will not be allowed to compete. If a safety concern is identified during the initial inspection, companies are permitted to modify their system and have it re-inspected. Companies are permitted to have their vehicle re-inspected twice. If a company fails to pass its third and final safety inspection, it is disqualified from the underwater competition portion of the event. There are NO APPEALS once an ROV has been disqualified.

Examples of safety violations from previous ROV competitions include:

- The electrical SID included in the technical documentation did not show a main fuse.
- The ROV used pneumatics, but the technical documentation did not include a pneumatics diagram.
- The ROV used pneumatics, but the company had not passed the fluid power quiz.

### 2.1 Job Site Safety Analysis

Each member of the company is encouraged to read [Oceaneering Americas Region HSE Employee Handbook](#), with emphasis placed on the following chapters.

Chapter 1 - Housekeeping

- Chapter 9 - Hand Safety
- Chapter 11 - Lifting and back safety
- Chapter 12 - PPE
- Chapter 17 - Tool Safety
- Chapter 24 - Electrical Safety
- Chapter 29 - Employee Observation Program
- Chapter 33 - JSEA
- Chapter 37 - Working at Other sights

**Job Site Safety Analysis (JSAs)**

For companies advancing to the international competition, up to 10 additional points can be earned by creating a JSA and submitting it along with (but as a separate document from) the [Technical Documentation](#).

A **JSA** describes job tasks in step-by-step fashion, identifies associated hazards at each step, and outlines proper hazard controls that minimize the risk of injury or illness to the individual(s) performing that task. JSAs are used extensively by the offshore industry.

For more information and examples, companies can visit the following web sites:

- <http://ehs.berkeley.edu/how-do-i-write-and-update-job-safety-analysis-jsa>
- [www.safetyworksmaine.com/safe\\_workplace/safety\\_management/hazard\\_analysis.html](http://www.safetyworksmaine.com/safe_workplace/safety_management/hazard_analysis.html)

**POTENTIAL HAZARDS**

DESCRIBE JOB STEP <small>(List the natural steps of the job. Do not make the steps too broad or too fine)</small>	POTENTIAL HAZARDS <small>(What are the potential hazards identified at this part of the job steps)</small>	RECOMMEND RISK CONTROL MEASURES <small>(describe how the identified hazards can be eliminated or reduced)</small>	RESPONSIBLE PERSON (S) <small>(Implementing control)</small>	INITIAL <small>(Of the responsible person/s)</small>
Toolbox Talk	Miscommunication	<p><b>ANYONE can call ALL STOP at any point if an unsafe condition /act is perceived/observed.</b></p> <p><b>Cell phone use is PROHIBITED in test area while testing!</b></p> <p>Ensure all participants are aware of procedures and roles within the procedure and sign JSEA acknowledging thusly.</p> <p>Ensure that all participants are wearing correct PPE (safety glasses, safety shoes, gloves, and hard hats if crane ops are being performed)</p> <p>Ensure participants/witnesses are wearing adequate clothing for weather conditions and to take breaks whenever necessary.</p>		
Hydraulic Function Testing	<p>Stored/Trapped Energy: Up to <b>12,000 PSI</b></p> <p>Environmental Discharge</p> <p>Tubing/Hose Failure</p> <p>Line of Fire</p>	<p>Ensure all functions have pressure/flow reduced to 0 PSI when not being actively function tested.</p> <p>Ensure each circuit is setup correctly before increasing pressure.</p> <p>Ensure Vent hoses are properly connected to fluid containment reservoir.</p> <p>Ensure all hoses are whip checked before coming up on pressure.</p> <p>Ensure valves and actuators are in proper configuration before testing.</p> <p>Ensure relief valves are set to relieve at the proper setting.</p>		

Example JSA task items courtesy of Oceaneering International

## 2.2 Safety Pre-Inspection

A safety pre-inspection will be completed before competition day. Companies will submit documentation to their regional coordinator; those advancing to the international competition will submit their documentation to the MATE ROV Competition officials.

Teams advancing to the international competition are required to submit the following:

- Technical documentation
- Company spec sheet
- SID [Electrical, Pneumatic & Hydraulic as utilized]
- Micro-ROV design document
- Micro-ROV SID
- Company safety review

See 2.2.1 Safety documentation requirements below for more information.

Regionals may not require all of these documents. Contact [your regional coordinator or visit your regional contest's website](#) to determine the required documents as well as the date and proper format for submission.

Once received, safety inspectors will conduct an **initial safety and documentation review** to identify potential safety violations. This review will be worth 20 points. Companies with violations will be notified via e-mail. Once notified, companies must:

- a. Respond acknowledging receipt.
- b. Layout a plan to address the violation.
- c. Submit new documentation if required.

Safety inspectors will also compile a list of the safety violations and publish them to the competition website. This is not done to “call out” or embarrass companies in any way. It is to emphasize the fact that EVERYONE is responsible and accountable for ensuring a safe, successful event. It also allows the company to correct the safety violations before arriving at the international competition.

While your regional's safety inspectors will review your documentation for safety, they may or may not award points. Contact [your regional coordinator or visit your regional contest's website](#) for more information.





### 2.2.1 Safety documentation requirements

Unless stated otherwise, each document **MUST** be submitted separately. In addition to the SID included in the technical documentation, an individual SID must be submitted for the initial safety inspection. The company safety review should not refer to systems shown in a submission video or detailed in the technical documentation.

DOC-001: SID Electrical: This must be an electrical diagram for all ROV systems. One section should focus on the systems above the waterline, and one section should focus on systems on the ROV (below the waterline). The SID:

- Should not exceed one 8.5" x 11" page in length (both above and below water sections, as well as any other information, should be on one page). Printed documents must be sized to fit on one side of the printed paper.
- Must be drawn with a CAD (computer assisted drawing) program. Hand drawn figures are not permitted.
- All symbols used should be standard symbols as specified by ANSI, NEMA or IEC.
- The SID must include a FUSE SYMBOL using an ANSI, NEMA or IEC symbol.
- The SID must not be component level schematics, but a higher level interconnection block type diagram. Do not include individual pins on a board; the SID is a higher level diagram.
- Fuse calculations must be included on the SID.

The following ANSI and IEC fuse symbols are all acceptable for MATE documentation.

Item	ANSI	IEC
FUSE		

An example of an acceptable SID can be found here:

- RANGER example:  
[https://www.marinetech.org/files/marine/files/ROV%20Competition/2019%20competition/Missions/MacauAnglicanCollege\\_FishLogic\\_SID%20electrical\\_2018.pdf](https://www.marinetech.org/files/marine/files/ROV%20Competition/2019%20competition/Missions/MacauAnglicanCollege_FishLogic_SID%20electrical_2018.pdf)

DOC-002: SID Fluid Power: Companies using fluid power **MUST** include a fluid power diagram using industry standard symbols, showing all items, regulators, and control valves. The diagram must document the components on the surface and the components located onboard the ROV. Fluid power diagrams must use ANSI, NEMA or IEC symbols. The fluid power diagram must also be drawn with a CAD program and should be a one 8.5" x 11" page diagram. The fluid power diagram may be included on the main electrical SID or as a separate one page document.

DOC-003: Companies utilizing an independent sensor or other electrically powered, non-ROV device to complete a product demonstration task must submit a SID for this device. The micro-ROV is a non-ROV device; companies must include an SID for their micro-ROV. This diagram must be completed to the specifications listed in DOC-001. The non-ROV device SID may be included on the main electrical SID or as a separate one 8.5" x 11" page document. Companies must include fuse calculations for the micro-ROV on their non-ROV device SID.

DOC-004: Micro-ROV Design: Companies will be required to submit a one page written and photographic description of their micro-ROV for drain pipe inspection. This document must specify whether your micro-ROV uses on board power or is powered from the primary ROV. If the micro-ROV uses onboard batteries, you MUST include the type of battery used. Companies should note whether their micro-ROV only uses fiber optic cabling to connect to the main ROV or whether copper wire carries power between the micro-ROV and main ROV.

DOC-005: Company safety review: All RANGER companies must submit a company safety review that demonstrates compliance with the following specifications:

- Anderson Powerpole connectors are the main point of connection to the MATE supply (ELEC-010R).
- A properly sized fuse is within 30 cm of the main point of connection. The company must use a ruler to show this distance (ELEC-008R).
- Fuse calculations (ELEC-008R).
- The inside of the control box is does not have exposed wiring (ELEC-017R), the control box is neatly laid out with attention to workmanship (ELEC-022R), a separation and identification of 120VAC wiring from DC and control voltages (ELEC-023R). If AC wiring is not used in the control box, include a statement saying no AC is used.
- The tether leading to the ROV has adequate strain relief (ELEC-024).
- If hydraulics / pneumatics are used that the company has passed the Fluid Power Quiz (FLUID-014). If fluid power is not used on the vehicle, include a statement saying no fluid power is used.
- Companies using only manually powered pumps should include information about the system.
- If used, hydraulic / pneumatic systems include a pressure release valve and regulator in the system (FLUID-007, FLUID-011), and that any pressurized cylinder, pressure storage device meets the MATE specifications (FLUID-012, FLUID-013).
- Any watertight housing on the vehicle can withstand pressure at 4 meters (MECH-001).
- All propellers are shrouded and have propeller guards (MECH-006).
- The ROV has no sharp edges or elements of the ROV that could cause damage (MECH-006, ELEC-017R).

The following photographs must be included within the company safety review:

- Anderson Powerpole connector within 30 cm of fuse (show fuse, ruler and connectors)
- Inside of the control box with wires labeled

- Strain relief where tether goes into ROV
- Compressor or pump (if pneumatics/hydraulics are used) including release valve and regulator
- Propeller shrouds (front and back of one propeller)

The company safety review should include an explanation of how each system meets the safety specifications and include photographs of the relevant systems for review by the MATE ROV Competition officials.

### **Initial Safety and Documentation Review points**

Penalty points will be deducted from the initial safety and documentation review if:

- Companies do NOT submit ALL the required documentation by the given 6.2 KEY DEADLINES.
- The SID does not show a fuse, or the fuse does not use an ANSI, NEMA or IEC symbol.
- Fuse calculations are not show on the SID.
- The vehicle uses fluid power, but a fluid power diagram is not included.
- The micro-ROV SID and design document is not included.
- The technical documentation is not submitted in a searchable PDF format.
- The technical documentation is over 8MB in size.
- Other documents are over 2MB in size.
- The company safety review does not show compliance with all of the specifications.

The initial safety and documentation review rubric can be found [here](#).

## **2.3 Onsite Safety Inspection**

Companies must complete their onsite safety inspection before their vehicles enter the water.

Companies advancing to the international competition must complete their safety inspection by the end of the first day of the competition. Companies must transport their vehicles to a designated room(s) where they will undergo their safety inspection. The inspector(s) will reference the list of violations as he/she conducts the safety inspection of the vehicle using the safety inspection rubric.

What follows is the safety inspection protocol used at the international competition. Consult [your regional coordinator or visit your regional contest's website](#) for more information about the safety inspection process used at your regional.

## **2.4 Safety inspection protocol**

1. Before entering the water for practice or a product demonstration run, the ROV system must go through a safety inspection. Once a company successfully passes inspection, they will turn in their safety inspection sheet to the safety inspector and receive a Blue PASSED Card with their company number on it. Companies must present the Blue PASSED Card to the pool practice/product demonstration coordinator before their vehicles are permitted to enter the water.

2. Competition staff will conduct a safety inspection of the vehicle using the [safety inspection rubric](#).
3. If the safety inspector(s) identify a safety violation, companies will have the opportunity to address it. The pool practice or product demonstration run schedule will NOT change to allow companies more time.
4. If during the second safety review the
  - a. violation has not been properly addressed or
  - b. another violation is revealedcompanies will have ONE additional opportunity to address the issue.
5. If during the third safety review a violation still exists, companies will not be permitted to participate in the underwater product demonstration component of the competition. However, companies can still participate in the engineering and communication (technical documentation, product presentation, and marketing display) component.
6. Reminder: All companies must present the Blue PASSED Card to the pool practice or product demonstration judge before placing their vehicles in the water. In addition, product demonstration station judges and competition officials can pause or stop a product demonstration run at any time if they feel that there is a potential safety concern.

**REMINDER!!!** Companies do not need to present their Blue PASSED Card to the judges during their engineering presentation. Companies that have their engineering presentations scheduled for the first day do not require an early safety inspection in order to participate in their presentation.

## 2.5 Safety Inspection Points

The safety inspection is worth 30 points. Each time a company fails its safety inspection it loses 10 points. After a company fails its second inspection, it must meet with the chief safety inspector to discuss a plan of action prior to returning to its workstation. THREE STRIKES and a company

- a. Receives 0 points for the safety inspections and
- b. Is disqualified from the underwater product demonstration component

## 3.0 SPECIFICATIONS

The ROV system must meet the following requirements:

### 3.1 Operational

#### 3.1.1 Multiple Vehicles

OPER-001: RANGER class companies are required to design and build ONE ROV that can complete the necessary product demonstration tasks. If companies choose to tackle the pipe inspection portion of Task 1, a second, micro-ROV must be constructed. When not conducting the inspection, the micro-ROV must be attached to or docked with the main ROV. "Floating eyeballs" or other vehicles that are not hard connected to the frame of the main vehicle are NOT permitted. Cameras designed to provide a

“birds-eye view” are permitted provided that these cameras are hard connected to the frame of the main vehicle. “Hard connection” does not include the wiring between the camera and the ROV. Other than the pipe inspection task, the micro-ROV may not move away from the main ROV to provide an additional camera view.

### *3.1.2 Environmental*

OPER-002: The ROV system must be able to function in fresh, chlorinated water with temperatures between 15 °C and 30 °C. The water should be considered conductive of electrical currents.

OPER-003: The pool will not be covered or purposefully darkened in any way, although the specific product demonstration tasks may require that your ROV operates in low-light.

OPER-004: No water currents will be intentionally created. However, depending on the venue, pressurized pool filtration system outlets may cause unexpected currents.

OPER-005: The pool venue at the international competition has a smooth bottom.

Note: Regional competitions may be held in pool venues with different environmental conditions than those listed here. If you are unfamiliar with the regional pool, contact [your regional coordinator or visit your regional contest’s website](#) for additional information.

### *3.1.3 Service Requirement*

OPER-006: Companies shall provide a crew of at least 3 but not more than 6 people on the pool deck to operate the ROV System. Companies can send a larger crew to the event, but no more than six can be on the deck at any time. More information about this “product demonstration team” is provided in the [COMPETITION RULES](#).

### *3.1.4 Maintenance and Calibration Requirement*

OPER-007: System maintenance during field operations shall be conducted by ROV personnel at their workstations. Work of any kind must not be done by company mentors or advisors. All maintenance parts and equipment necessary to meet the operation requirements shall be provided by the company. More information about these regulations is provided in the [COMPETITION RULES](#).

OPER-008: All measurement devices shall be calibrated according to manufacturer recommended calibration procedures and performed by company members only. Company mentors or advisors are not permitted to perform calibration procedures. More information about mentor restrictions is provided in the [COMPETITION RULES](#).

## **3.2 Mechanical/Physical**

This section of the document provides specifications for the mechanical properties of the ROV system.

### *3.2.1 Materials*

MECH-001: Any components or electronics housings on the ROV shall be capable of operating to depths of 4 meters.

### *3.2.2 Size and Weight*

MECH-002: ROVs are limited to a maximum diameter of 85 cm. Vehicles above this size will not be allowed to compete. ROVs are also limited to a maximum weight, in air, of 25 kg. Vehicles over this weight will not be allowed to compete. Companies must be able to personally transport the vehicle and associated equipment to the product demonstration station and to the product presentation room. ROV systems must be capable of being safely hand launched. Additional points will be given to smaller, lighter vehicles (see **SIZE AND WEIGHT RESTRICTIONS**).

### *3.2.3 Tether Length*

MECH-003R: At the international competition, ROVs must be capable of operating in a maximum pool depth of 3 meters (10 feet). All underwater product demonstrations will take place within 8 meters from the side of the pool. The product demonstration station will be no more than 3 meters from the side of the pool. Tether length should be calculated accordingly. Regional competitions may be held in pool venues with different maximum depths than those listed here. If you are unfamiliar with the regional pool, contact [your regional coordinator or visit your regional contest's website](#).

### *3.2.4 Vehicle Deployment and Recovery*

MECH-004: The ROV system must be launched and recovered manually; no powered winches or portable cranes can be used. Hand-powered lifts and levers may be used to launch and recover the vehicle. The vehicle and any associated equipment must not damage any part of the pool or pool deck.

MECH-005: Any hand-powered lift or levers that are used as a LARS must be detailed in the technical documentation and must be part of the safety inspection procedure. Any LARS equipment that is deemed as unsafe at the safety inspection will not be allowed. Ladders, tripods, or other bracing equipment are not permitted as part of a LARS.

### *3.2.5 Propellers*

MECH-006: Propellers must be shrouded and have thruster guards. ROVs that have propellers exposed without thruster guards will not pass the safety inspection and will not be allowed to compete. A shroud must completely encircle the propeller and extend at least 2 mm in front of and behind the propeller. Thruster guards must completely cover any openings on the thruster and should have a mesh size that meets [IP-20 standards](#) (solid particulate protection level 2). This IP code equates to a mesh size >12.5 mm. To pass safety inspection, the shroud and propeller guard should meet this standard. If your finger can touch the propeller, then it is not properly guarded.

Teams may construct thruster guards, 3D print thruster guards, or may purchase commercially available thruster guards. All motors on the ROV must be protected with shrouds and thruster guards.

See <https://www.thingiverse.com/thing:1498338> for an example of an acceptable thruster guard.

### 3.3 Electrical

ELEC-001: All power provided to the ROV system through an external connection for any purpose during the competition must be obtained from the MATE competition power supply. This includes dedicated lines for cameras, manipulators, and any other devices. This is a singular point of connection; all power to the ROV must pass through the MATE-provided fuse AND the single in-line fuse as specified in this section.

#### **NOTE FOR 2019!!!**

Circuit breakers will not be allowed on the ROV system. Companies must use an inline fuse(s).

ELEC-002R: The ROV system must be capable of operating off the power provided by a MATE supply with a nominal voltage of 12 VDC. This voltage may be as high as 14.8 volts. At the international competition, power for the RANGER class will be provided by isolated power supplies. At regional competitions, power may be provided by isolated power supplies or batteries. Contact your regional coordinator or visit your regional contest's web site if you have questions about the type of power source being used. Your system should be designed to work with the maximum specified voltage of 14.8 VDC.

ELEC-003R: The ROV system may deliver any voltage to the ROV at or below the nominal supply voltage provided. Conversion of this voltage is allowed prior to it arriving at the ROV.

ELEC-004R: ROV systems may use any voltage desired up to 12 volts.

ELEC-005R: Voltage may not be increased above the nominal 12 volts anywhere in the ROV system.

ELEC-006R: Sonar or other systems that may have DC/DC conversion resulting in voltages above 12 V nominal are not permitted.

ELEC-007R: Voltages in excess of the class parameters set forth in this specification are not allowed on the ROV system at any time other than any inductive spikes that are caused by the switching on/off of motors, solenoids and other inductive devices. Companies should design their systems to handle these voltage spikes but will not be penalized for the presence of these in a system. For additional information on this, companies can research back electromotive forces (back EMF), collapsing magnetic motor fields, and transient suppression.

#### 3.3.1 Non-ROV Device Power Specifications

In 2019, the micro-ROV deployed from the main ROV falls under the following NRD power specifications.



ELEC-NRD-001: Non-ROV devices can be powered from the surface running through the ROV (and ROV tether) or from batteries onboard the device. Power is limited to 12 VDC maximum and 6 amps maximum.

ELEC-NRD-002: The micro-ROV may contain thrusters and cameras.

ELEC-NRD-003: If powered from the surface through the ROV, the micro-ROV must have a 7.5 amp (or smaller) fuse at the point of connection to the ROV.

ELEC-NRD-004: Onboard power is allowed for non-ROV devices. If onboard batteries are being used, the following specifications must be met:

- Batteries must be primary (non-rechargeable).
- AAA, AA, A, A23, C, D or 9V alkaline batteries are allowed. No other size or chemical composition is allowed. 12 volt, outdoor, rechargeable batteries are **NOT** allowed. High discharge LiPo batteries are **NOT** allowed.
- Batteries are mounted in a manner that they are not loose inside the container.
- A fuse (7.5 amps max) must be installed within 5 cm of the battery positive terminal.
- The enclosure housing must be designed so that it will open if the pressure inside the housing is greater than the outside pressure.
- Any pressure relief plug **MUST** be at least 2.5 cm in diameter. Smaller plugs will not pass safety inspection.
- Under no condition should the housing be built with fasteners to hold the device together. At least one opening must serve as a pressure release.
- Utilization of pressure release valves is not acceptable as they cannot be tested at the competition site.
- The battery holder must be mounted in a manner that will allow the end cap to freely open if pressure develops inside the housing.

Examples of acceptable methods for housing batteries include:

- A PVC pipe with wires penetrating one end and the opposite end plugged with a pressure relief plug (rubber stopper, etc). Note: Any pressure relief plug **MUST** be at least 2.5 cm in diameter. Smaller plugs will not pass safety inspection.
- Cylinder with batteries mounted inside. One end of the cylinder sealed with caps and O-rings, but no fastening devices holding the end cap on.

ELEC-NRD-005: An SID must be submitted for any non-ROV device that uses electrical power.

### *3.3.2 Independent Sensors*

Certain product demonstration tasks may require a sensor that is independent of the vehicle. These electrically powered sensors will operate under the following independent sensor rules.

ELEC-IS-001: Independent sensors must be powered from the surface; no onboard batteries are allowed.

ELEC-IS-002: Companies may use USB to connect their sensor to a computer. Companies may also use surface battery packs (limited to 12 volts maximum) or the MATE supply to provide power for their independent sensor.

ELEC-IS-003: The independent sensor may only contain the intended sensor; thrusters, cameras, or other systems MAY NOT be attached.

ELEC-IS-004: Companies that use an independent sensor must provide a 3 amp (or less) fast blow fuse on the positive side of their connection. If companies are using the 12 volt MATE supply to power their sensor, both the ROV and the sensor must run through the single fuse before splitting off to the 3 amp sensor fuse. Companies using USB only to power an independent sensor may utilize the built-in current limiting of USB and do not need to add an additional fuse.

ELEC-IS-005: An SID must be submitted for any independent sensor that uses electrical power.

### *3.3.3 Current*

ELEC-008R: ROVs will be limited to 25 amps.

The ROV system must have a fuse that is calculated based upon the maximum current draw of the ROV. This overcurrent protection must be calculated as follows: ROV Overcurrent Protection = ROV Full Load Current \* 150%. The overcurrent protection value may be rounded up to the next standard fuse. The ROV Overcurrent protection value may exceed 25 amps, but companies are limited to a 25 amp fuse. Companies must use the fuse that is rated for their overcurrent protection. Companies that use a fuse larger than their calculated value will not pass safety inspection. The fuse must be installed in the positive power supply line within 30 cm of the power supply attachment point. The fuse may be a slow blow type. The SID and other electrical diagrams must show the fuse and include the amperage of the overcurrent protection. In addition, the SID must show the calculations used in determining the overcurrent protection value. SIDs without these calculations shown will have points deducted from the initial safety inspection and documentation review. Also, SIDS without fuse calculations will not pass safety inspection. The motor current used must be full load current while in water, not while operating in air. Overcurrent calculations using the lower current values will be rejected.

ROV overcurrent protection example 1:

- Four motors, 2.7 amps each = 10.8 amps
- Two cameras = 0.25 amps
- Two servo motors = 0.8 amps
- One laser = 0.02 amps
- Total Amps: 11.87 amps X 150% = 17.8 amps
- ROV uses a 20 amp fuse

ROV overcurrent protection example 2:

- Six motors, 3.7 amps each = 22.2 amps
- Two cameras = 0.85 amps
- Two servo motors = 0.8 amps
- One laser = 0.02 amps
- Total Amps: 23.87 amps X 150% = 35.8 amps
- ROV uses a 25 amp fuse

All information on overcurrent protection should be included on the SID. Show your work.

The MATE power supply will be protected by a 25 amp fuse; however, the ROV system must also have its own calculated fuse.

ELEC-009R: ROV systems are allowed one replacement fuse during the product demonstration. In the event that the ROV system blows the second fuse during the demonstration, time will stop, the demonstration run will be over, and no additional points will be earned. Companies should have adequate replacement fuses on hand, MATE will not provide replacements. Standard sizes for fuses are 15, 20, and 25 amps. Additional standard fuse sizes are 1, 3, 6, and 10 amps.

### *3.3.4 Power Connections*

ELEC-010R: Power supply connections will be red/black Anderson Powerpole Connectors. Companies' ROV system power wires must have proper connectors to obtain power. The Anderson Powerpole Connectors must be connected to the ROV power wires securely; use of a proper mechanical crimper is suggested. Hand crimp tools do not have the force necessary to ensure proper and safe connections. MATE will not provide companies with connectors or adapters at the 2019 International Competition.

#### **NOTE FOR 2019!!!**

The red and black pole pieces must attached together. Loose Powerpoles (those not attached together) will not pass safety inspection.

<http://www.andersonpower.com/us/en/products/powerpole/pp15-to-45.aspx>

These are two-piece connectors as shown in the picture below.



Part specification and part numbers

Anderson Powerpole – red and black connector with 30 amp contacts

Red is connected to power supply positive.

Black is connected to power supply negative.

Since Anderson sells the connectors in 2500 and 200 piece quantities, these connectors are available from distributors.

Distributor Part Number:

Connector & Pins: PowerWerx WP30-10 (This is a kit with 10 connector sets and 30 amp pins for approx \$12 USD)

Recommended Crimper: TRICrimp

<http://www.powerwerx.com/crimping-tools/tricrimp-crimping-powerpole-contacts.html>

Connector Sources:

<http://www.powerwerx.com/anderson-powerpoles/powerpole-sets/30-amp-permanently-bonded-red-black-anderson-powerpole-sets.html>

<http://www.aesham.com/power-distribution/powerpoles/powerwerx-wp30-10/>

[http://www.gigaparts.com/Product-Lines/Power\\_2/Powerwerx-WP30-10.html](http://www.gigaparts.com/Product-Lines/Power_2/Powerwerx-WP30-10.html)

<http://www.hamradio.com/detail.cfm?pid=71-001833>

### **Powerpole related links**

Powerpole Data Sheet

<http://www.andersonpower.com/global-assets/downloads/pdf/ds-pp1545.pdf>

Powerpole Description

[https://en.wikipedia.org/wiki/Anderson\\_Powerpole](https://en.wikipedia.org/wiki/Anderson_Powerpole)

Powerpole Assembly Instructions

<http://www.powerwerx.com/assembly.asp>

<http://www.wb3w.net/powerpoleinst.htm> (see the section on using the TriCrimp tool)

YouTube video for Assembly

Part 1: [https://www.youtube.com/watch?v=8\\_DPPuQN8R4](https://www.youtube.com/watch?v=8_DPPuQN8R4)

Part 2: <https://www.youtube.com/watch?v=EsSsr2zGFqI>

ELEC-011R: The power supply may be located up to 1 meter from the station table and may be located on either side of the table. MATE recommends a power cable long enough to reach the power supply up to 3 meters from your control system.

### *3.3.5 Tether Voltages*

The signals in the tether must meet the following specifications:

ELEC-012R: DC main supply at a nominal voltage of 12 VDC as provided by the MATE power supply.

ELEC-013R: Low voltage, low current AC or DC control or sensor signals. Low voltage is defined as a voltage equal to or less than the maximum supply voltage per class specification. Low current is defined as being less than 500 mA. Examples include video signals, control signals for electrically powered manipulators, sensor signals, etc.

Note: Companies concerned about how voltage loss will affect their camera(s) should consider adding a separate line in the tether to supply the camera from the main power source. This dedicated line for cameras is permitted, provided it runs through the single fuse.

ELEC-014R: Ethernet, USB, or other ANSI or IEC accepted serial protocol signals.

All cameras, including USB cameras, must be powered by the MATE supply. Powering a USB camera from the MATE supply can be accomplished by using a USB repeater / extender that has a separate power input at the far (ROV) end. The ROV would then provide the power to the device from the MATE supply. USB cameras directly plugged into laptops or surface computers are not allowed. Be sure to denote camera power on your SID.

**NOTE FOR 2019!!!**

If a company is using fiber optics and onboard power from their Micro-ROV, cameras on board the micro-ROV may be powered from onboard batteries.

ELEC-015R: NTSC or PAL Video signals

ELEC-016R: Fiber optic cabling of any type may be used.

*3.3.6 Exposed Connections and Disposable Motors*

ELEC-017R: ROVs with electrical connections that are exposed to water and not sealed are not permitted to enter the water. Taping a connection with electrical tape only does not constitute a sealed connection. The process of sealing electrical connections must include methodologies such as, but not limited to, Silicone RTV, hot melt glue, epoxy, self-vulcanizing tape, and enclosure of the connections in a housing.

ELEC-018R: “Disposable motors” are not permitted; these are exposed motors with no waterproofing.

Brushless motors must be properly waterproofed. Companies must either provide manufacturer documentation showing their brushless motors are waterproof or must properly waterproof their motors and provide documentation showing their methodology. Non-sealed brushless motors will not pass the safety inspection.

See [MATE Technical Bulletin #1](#) for proper methods to waterproof a brushless motor.

### 3.4 Onboard Electrical Power

ELEC-019R: Onboard electrical power (i.e., power not provided by the tether): Onboard battery power is not allowed on the primary ROV. See the [3.3.1 Non-ROV Device Power Specifications](#) regarding onboard power for the micro-ROV.

NOTE: Water leaking into a closed battery container can result in the generation of hydrogen gas. This gas can build up inside a pressure housing and create an unsafe situation. Any battery housing must be designed to open if the pressure inside the housing is greater than the outside pressure to meet the MATE safety standards. See the non-ROV device onboard battery rules (ELEC- NRD-004) for more information.

### 3.5 Power Shutdown

ELEC-020R: For safety purposes, any ROV system that is disconnected from the surface supply must stop functioning in less than 5 seconds. This applies to electrical, pneumatic, and hydraulic power sources. Any filters, capacitors or accumulators must be sized accordingly to meet this specification.

### 3.6 Fluid Power

Any vehicle using fluid power must provide a fluid power diagram. Fluid power is defined as hydraulic pumps (water) or pneumatic pumps (air) on the vehicle or on the surface.

#### 3.6.1 Hydraulic Power

FLUID-002: Hydraulic fluid: Water or biodegradable food-grade fluid, only.

FLUID-003: If a biodegradable food-grade fluid is used, a Material Safety Data Sheet (MSDS) must be provided at the safety inspection. The MSDS must show the type of fluid used and its compatibility with the Biodegradable Food-Grade specification. Companies using water do not need to provide an MSDS.

FLUID-004: The following fluids are approved for use in hydraulic systems:

- a. Water
- b. Biodegradable Food-Grade Hydraulic Oil ISO Grade 32/46, SAE Grade 20, McMaster-Carr part# 3499K22

All other bio-degradable food-grade fluids must be approved by the [Competition Technical Manager](#) by April 1, 2019.

FLUID-005: Maximum Hydraulic pressure allowed: 10.33 bars (150 psig).

#### **NOTE FOR 2019!!!**

FLUID-006: Hydraulic system: All lines, fittings, and hydraulic devices must be rated for a minimum pressure of two (2) times the maximum supply pressure.

FLUID-007: Hydraulic pumps must be part of the safety inspection.

1. They must have a pressure relief valve with a maximum setting of 300 psig or less installed before the pressure regulator.
2. The pump must have a regulator in place and set to 150 psig or less.
3. Pumps with any sign of external rust or deterioration will not be accepted.
5. All wiring must be secure.
6. All guards must be in place.
7. Hydraulic pumps may run off of the 15 A 115 VAC outlet provided for command and control as long as the hydraulic fluid is not used to propel the ROV. The hydraulic fluid is to be used for grippers and actuators only.

### *3.6.2 Pneumatic Power*

FLUID-008: Pneumatic fluid: Compressed air or inert gas only

FLUID-009: Maximum pressure allowed: 2.75 bars (40 psig)

#### **NOTE FOR 2019!!!**

FLUID-010: Pneumatic system: All lines, fittings, and pneumatic devices must be rated for a minimum pressure of two and a half (2.5) times the maximum supply pressure. For example, if an 83 bar (1200 psig) tank is regulated to 2 bars (30 psig), then all system components must have a minimum rating of 5.17 bars (75 psig). **Note: Aquarium tubing is not generally rated for the pressures associated with compressed gas systems and should not be used in a pressurized pneumatic system.**

FLUID-011: Air compressors must be part of the safety inspection.

1. They must have a pressure relief valve installed before the pressure regulator.
2. The compressor must have a regulator in place and set to 40 psig or less.
3. Compressors with any sign of external rust will not be accepted.
4. The tank drain valve must open.
5. If more than 5 ml of water exits upon opening the drain valve, the compressor will not be accepted.
6. All wiring must be secure.
7. All guards must be in place.
8. Air compressors may run off of the 15 A 115 VAC outlet provided for command and control as long as the air is not used for motor thrust. The air is to be used for buoyancy/ballast, grippers and actuators only.

### *3.6.3 Pressurized Cylinders*

FLUID-012: Pressurized cylinders may be used, but must remain above the water surface and meet the following specifications:

- a. Approved by US DOT (Department of Transportation) or TC (Transport Canada). For regional competitions taking place outside of the US, check with your regional coordinator for approval.



- b. Have a current official inspection/test sticker and/or stamp.
- c. Stamped with the maximum allowable pressure.
- d. Contain a pressure relief safety device.
- e. May be filled up to the maximum allowable pressure of the cylinder.
- f. Must be regulated at its output to a maximum of 2.75 bar (40 psig).
- g. Must have an easily accessible shut-off valve that is clearly marked with instructions.
- h. May only be stationed on the surface, not on the ROV.
- i. Must be secured in a safe manner such that they will not fall or roll around. If the judges feel that a cylinder is unsafe, they have the discretion to prevent its use.
- j. SCUBA tanks are permitted. They must meet all the above specifications and have a current visual inspection sticker, or “fill permit” visible.

**NOTE FOR 2019!!!**

Electronic housings and other enclosures on the ROV must operate at surface pressure. Companies may not pressurize their electronics housing.

*3.6.4 Unpressurized Containers*

FLUID-013: Companies may fill containers on the ROV with air provided those containers never exceed ambient pressure. Any such container should have at least one ¼-inch (6.35 mm) hole drilled into the bottom of the container to allow excess air to spill out.

*3.6.5 Pressure Storage Devices (Pressure Accumulators)*

FLUID-014: Pressure storage devices are allowed on the ROV if they do not exceed 1.25 L in total storage and do not store pressure higher than the allowed pressure for air or hydraulics. It is understood that companies may not be able to purchase a pressure accumulator that has the proper rating and fits in the space needed. In that case, the company must show that their designed accumulator is capable of withstanding the specified pressures without rupture.

*3.6.6 Chemical Creation of Gases*

The chemical creation of gases is not permitted.

*3.6.7 FLUID POWER QUIZ*

FLUID-015: RANGER class companies planning to use hydraulics and/or pneumatics (i.e., fluid power) are required to take and pass an online quiz with a score of 100%. Companies ONLY using manual pumps and unpressurized containers are not required to take the Fluid Power Quiz, but must still submit documentation regarding their fluid power system.

NOTE: The quiz was developed by MATE ROV Competition technical support staff and competition judges and is designed to ensure that companies understand basic information on these topics and can

apply that knowledge to safe practices. The intention is not to add yet another “requirement,” but rather to provide a safe and successful learning experience and competition environment.

The quiz should be completed by the STUDENT company members. Each member of the company does NOT have to take the quiz; students can work together and make it a group effort. **ONLY ONE TEST PER COMPANY.** The company’s instructor or mentor can provide guidance and advice, but the questions should be answered by the students participating on the company. The quiz will be scored and the results provided instantaneously. A score of 100% is considered a passing grade. Companies can take the quiz as many as 5 times to achieve this score.

**The quiz must be completed with a passing grade by April 1<sup>st</sup>, 2019.** Companies failing to complete this quiz within the given time frame will NOT be permitted to use fluid power during their competition event. **See special notes about fluid power quiz dates in [6.2 KEY DEADLINES](#).**

**FEE TO TAKE THE FLUID POWER QUIZ!** The fee to take the fluid power quiz is \$15 for five attempts (no discounts for fewer attempts) and must be paid for at the time of registration. Companies will see an option to purchase the fluid power quiz when they register. Within five business days of receipt of payment, companies will receive a link, username, and password to take the quiz.

Note: The login information will be sent to the email address used when creating the team/company within the Active registration system – it must be an accurate and current email or you will not receive quiz access.

The following are sources of information on hydraulics and pneumatics. This is not intended to be an exhaustive list, but rather a starting point to encourage companies to seek out additional information and resources.

- Underwater Robotics: Science, Design & Fabrication, published by the MATE Center and MATE Inspiration for Innovation – (see [www.marinetech.org/underwater\\_robotics](http://www.marinetech.org/underwater_robotics))
- <http://www.fxsupply.com/pneumatics/psafety.html>
- <http://mining.state.co.us/safety/downloads/ppoint/HydraulicPressureIntensification.ppt>
- National Fluid Power Association – <http://www.nfpa.com/education/mini-book.asp>
- Parker Hannifin Corporation – <http://www.parker.com/> (look for technical literature links)

### 3.7 Control Systems

ELEC-021R RANGER companies are not limited to the type of control system they may use provided it complies with the other MATE design and safety specifications.

ELEC-022R: Surface control stations must be built in a neat and workmanship like manner. Loose components and unsecured wires will not pass safety inspection.

ELEC-023R: Surface control stations by nature may combine 120 VAC and 12 VDC wiring. The surface control stations must be wired in a manner such that the 120 VAC wiring is physically separated from the DC wiring, the 120 VAC wiring is clearly identified from the DC and control voltages, and every

conductor is insulated in a manner that no conductor is exposed. Identification can be through signage and/or wire color schemes. All 120 VAC wiring colors must use ANSI, NEMA or IEC standard wiring colors appropriate to each voltage. There must be a sign inside the surface control station indicating which wiring standard is being utilized. Companies that do not have adequate separation of AC wires and components and DC wires and components will NOT pass the safety inspection. It is recommended that separation be designed into the control system to keep power systems separate. Wiring should be clear, neat, and easy to follow by inspectors. Wiring “rat’s nests” or “spaghetti wiring” will not pass safety inspection.

ELEC-024R: Companies must use proper strain relief and abrasion protection where wires and the tether enter the vehicle and the control box. The ROV should be capable of being lifted by the tether without damaging the tether connection to the ROV. Tape, glue, zip ties, and other quick methods of strain relief are not acceptable. The intent is to see the wires pass through a connector specifically designed to provide strain relief.

ELEC-025R: Any connectors utilized in the surface control station and elsewhere in the ROV system must be properly type rated for their application. AC rated connectors must not be used for DC. The connectors must also be rated at or above the voltage and current used in their application.

### 3.8 Command, Control, & Communications (C3)

#### 3.8.1 Power Provided

CCC-001: Surface power: MATE will provide one GFI-protected outlet with a nominal 115 Volts AC (60 Hertz) and 15 amps maximum. This outlet is intended to provide power for pumps and other surface support equipment (e.g. video monitors & control boxes). This AC power source CANNOT be used to directly or indirectly power the vehicle.

CCC-002: If hydraulic or pneumatic power is used for vehicle thrust, the power for the pump must come from the MATE supplied DC power supply.

CCC-003: In addition to electric pumps, hydraulic, and pneumatic systems can be powered by manual pumps (e.g. bicycle tire pump) or supplied from a pre-pressurized cylinder. Companies that are only using manual pumps must still comply with all hydraulic and pneumatic specifications, including the creation of a fluid power SID.

#### 3.8.2 Displays

CCC-004R: Companies are limited to a maximum of three video display screens. Companies may use an additional two displays for ROV status or sensor information.

CCC-005R: These display devices may be powered by the MATE provided GFI-protected 115 volt AC (60-cycle) and 15 amp AC power source described in CCC-001, Surface power.

CCC-006R: A company's C3 station may include devices like video recorders. All C3 devices must be able to run on the single AC power outlet provided or on its own internal battery power. Any device plugged into this AC power outlet can only provide C3 functions and cannot provide power to the ROV.

### 3.9 MATE Provided Equipment

For companies advancing to the international competition, MATE will NOT provide video monitors at the product demonstration stations. Contact your [regional coordinator or visit your regional contest's website](#) as to whether video monitors will be provided at your regional competition.

#### 3.9.1 Companies Sharing Equipment

Companies may be allowed to share the following equipment during the competition event: monitors, joysticks, and compressors.

Companies may NOT share the following equipment during the competition event: control systems and payload tools (e.g. grippers, manipulators).

Contact your [regional coordinator or visit your regional contest's website](#) to determine if equipment can be shared at your regional event.

Companies that plan to share equipment during the international competition event must notify the [Competition Technical Manager](#) at least 4 weeks prior to the event so that this can be considered when creating the schedule. MATE will do its best to accommodate companies sharing equipment.

### 3.10 Laser Safety Rules

LASR-001: **Companies using a laser at the competition must inform the MATE ROV Competition officials and provide the laser specifications by April 1<sup>st</sup>, 2019.** Information and laser specifications should be sent to the [Competition Technical Manager](#). Specifications will be forwarded to the MATE ROV Competition safety inspection team for evaluation. Once the laser specifications are reviewed, a notification will be sent to the company. If the laser is being used at a regional event or pool practice, notification will also be sent to the regional competition coordinator.

LASR-002: All lasers must operate in the visible range at either the 630-680 nm (red) or near the 532 nm (green) wavelength. All lasers must fall into the Class I, Class II, or Class IIIa category. Red lasers must operate at 5mW or less. Green lasers must operate at 1 mW or less.

LASR-003: Companies should include detailed specifications of their laser in their technical documentation as well as have that information ready and available during their safety inspection and product presentations.

LASR-004: Lasers must have an on/off switch. This switch must be on the surface controller.

LASR-005: All lasers must be powered by the MATE surface power supply. Batteries, including batteries for powering lasers, are not permitted on the vehicle.

LASR-006: Companies using lasers cannot increase the voltage or the current to increase the power of their lasers. Lasers must use the voltage and current set in their specifications.

LASR-007: When out of the water, the laser should have a shield or enclosed beam stop attachment within 30 cm of the laser. This means that the laser beam should not travel more than 30 cm before reaching the shield. This is a requirement at all times when the laser is out of the water. The shield does not need to be attached to the ROV while it is in the water. The shield must be painted with FLAT BLACK paint.

LASR-008: At no time should the laser be focused or deviate from a collimated beam.

LASR-009: When testing the laser at a workstation, companies must display a sign telling others that a laser is being operated.

LASR-010: Operators working with the laser while the ROV is out of the water should wear appropriate laser safety glasses at all times. This requirement is for all laser types. Search online to find laser safety glasses appropriate for the wavelength being used.

**Companies must forward the specifications of their laser safety glasses to the [Competition Technical Manager](#) by April 1<sup>st</sup>, 2019.** A notification will be sent to the company when the laser safety glasses are approved. Companies must also bring a copy of their laser safety glasses specifications to their safety checks. If more than one brand of glasses are used, a copy of each specification sheet should be provided.

## PART 4: COMPETITION RULES

### 4.1 GENERAL

- All members of the company and their supporters must follow the safety regulations of the ROV competition, pool facility, and event venue.
- All company members and their supporters are expected to conduct themselves in a professional and responsible manner during the competition. Disrespectful behavior towards the judges, officials, pool staff, audience, or other companies will lead to penalty points or disqualification.
- Sabotaging, stealing, or pilfering equipment of other companies will lead to disqualification. Companies found cheating will also be disqualified.

- The MATE ROV competition is, at its core, designed to be an educational and inspirational event for **STUDENTS**. It is designed to challenge them to apply the physics, math, electronics, and engineering skills they are learning in the classroom to solving practical problems from the marine workplace. (See the [MATE Competition Philosophy](#).)

It is expected that all “adults” (non-students; e.g. teachers, mentors, parents) involved in the competition limit their input to educational and inspirational roles. Actual construction of the ROV (particularly in the complex electrical and software areas) must be completed by the students. Adults should teach and advise students about design, electronics, software, and construction, but not complete the work for the students. Throughout the process adults are encouraged to focus on benefits to the students from the process and not simply winning. If it becomes apparent that adults exercised more than an advisory role, judges reserve the right to deduct points or, in extreme cases, disqualify companies from the competition.

ALL work done on the vehicle must be conducted by company members. This includes any work done at home, at school, or during the MATE ROV competition (international and regional). Teachers, mentors, parents, and non-competing students are not permitted to work on the ROVs. They may provide advisory input, but they may not work on the ROV directly. This includes writing or editing software code. All mechanical, electrical, and software modifications and/or repairs to the ROV must be completed by students.

With learning at its core, the MATE competition encourages students to utilize and build upon their skill sets to find creative solutions to designing and building their ROV. Students gain valuable skills and knowledge when creating a component from “scratch,” which is apparent to judges as they review the technical documentation and engineering presentation. However, as they move through the process of analyzing their designs and identifying building materials, students may decide to either build a component from “scratch” or purchase it from a commercial vendor.\*\*\* So, while original solutions are encouraged, the use of commercial components is acceptable, provided 1) that the components adhere to the design and building as well as safety specifications for the particular competition class and 2) more importantly, that the students can provide a reasonable, logical explanation for buying versus building.

The competition scoring rubrics are designed to reflect this; points are awarded based on students’ abilities to explain and justify how all of the components and systems work together as an integrated ROV, regardless if they purchased them, pulled them from public libraries, or made them themselves.

\*\*\*Note “commercial vendor” includes the SeaMATE store and other competition programs that sell educational robotics kits. SeaMATE kits were created to remove barriers to participation for teachers and schools unable to easily 1) find parts and materials and 2) set up accounts with multiple vendors. The kits are part of a larger educational package offered by the MATE Center that includes curriculum materials, videos, and other resources to support and enhance learning. And

learning is what students who use SeaMATE (or other) kits will be expected to demonstrate during and through the [ENGINEERING & COMMUNICATION](#) components.

It should be noted that purchasing and competing with complete, assembled, commercial ROVs is not permitted.

## 4.2 PROCEDURAL

- Companies must compete during their assigned time slots. Your company is **NOT** permitted to switch time slots with another company. Failure to show for your scheduled product demonstration or for your company's product presentation will result in "no score" for that particular competition category. **No exceptions.** Assigned time slots will be sent out in advance so that any scheduling concerns can be addressed prior to the event.

\*Regional contests may refer to the product demonstration station as the control "station" or "shack."

- Companies must complete their size and weight measurements before each product demonstration run. The size and weight measurements are included as part of the product demonstration score. Companies should be at the size and weigh in area at least 20 minutes before their scheduled product demonstration run.
- While there is no limit to the number of students who can compete as part of a company, **the product demonstration team (aka demo team) is limited to six students.** The demo team is defined as the team of students who operate the vehicle and its associated equipment during the product demonstration. Only six students will be allowed to enter the product demonstration station, launch, pilot, and perform the tasks. Instructors, mentors, and/or non-student members cannot participate as part of the demo team. **Companies may alternate students on the demo team for the two product demonstration attempts.** (All members of the company should participate in the engineering and communication components; see [ENGINEERING & COMMUNICATION](#) for more information.)
- Only the demo team members and judges are allowed at the product demonstration station during the product demonstration, which includes the set-up and demobilization periods. Other members of the company, instructors, mentors, audience members, and observers (press or special invited guests) must remain outside the product demonstration station or in designated viewing areas.
- Instructors, mentors, parents, and "fans" are **NOT** permitted at the safety inspection stations or repair tables. Two warnings will be issued before individuals not heeding this rule will be asked to leave the venue.



- In addition, instructors, mentors, parents, and fans are **NOT** permitted to work on the ROV. Individuals who are seen working on the ROV who are not student company members will be issued a warning. Two warnings will be issued before individuals not heeding this rule will be asked to leave the venue. If companies choose to take their ROVs off the competition grounds for maintenance and repair, they are expected to observe this rule in the interests of the spirit of the competition.
- To help enforce this, teachers, mentors, parents, and non-competing students MAY have limited access to the work station areas. Contact [your regional coordinator](#) or the [MATE ROV Competition officials](#) for more information.
- Video devices may be used to record the underwater activities for entertainment and learning purposes **only**. Video will not be used as an instant replay to review judges' decisions or to challenge product demonstration timing.
- Product demonstration stations will be roped off and marked. Product demonstration stations will contain 2-3 chairs and one 6-foot table long table for companies to use. This table will be within 3 meters of the pool edge. Product demonstration stations will be set up to prevent the pilot(s) from looking at the ROV in or under the water except through the ROV cameras.
- Companies will compete in one product demonstration that will consist of three tasks. Companies will get TWO attempts at the one product demonstration. The higher of the two scores will be added to the engineering and communication score to determine the total, overall score for the competition.
- The product demonstration time consists of a 5-minute set-up period, a 15-minute performance period, and a 5-minute demobilization period. If the demo team and all of their equipment are not out of the product demonstration station at the end of the 5-minute demobilization period, the company will be **penalized 1 point for each additional minute**.

**Note:** Regional competitions *may not* offer two attempts at the product demonstration. Regional competitions may allow more or less time to complete the product demonstration. Contact [your regional coordinator](#) or [visit your regional contest's website](#) for more information.

- Manipulating the tether to free it from underwater obstacles is permitted. Pulling on the tether to speed up the recovery of items or to return your vehicle more quickly to the surface is not permitted and will result in penalty points. Judges will issue one warning if tether pulling occurs. Each future infraction will result in **5** points deducted from the final product demonstration score.
- SCUBA diver assistance will be available at the international competition. If help is required, the company CEO or pilot must ask a station judge and divers for assistance. Each diver assist will incur

a 5 point penalty. The product demonstration clock will not stop if a company is receiving diver assistance.

Diver assistance may not be available at your regional competition. Contact [your regional coordinator or visit your regional contest's website](#) to determine if diver assistance will be available at your regional competition.

- Pilots can only leave the product demonstration station and move poolside to repair, adjust, or alter a vehicle if the ROV is surfaced and at the side of the pool.
- Companies are not permitted to leave debris in the pool. Any debris must be recovered by the ROV before time has expired or the company will be penalized. Debris is defined as pieces of the ROVs, weights, floats, or other items created by the company. A company's cannon lift mechanism is not considered debris. Task props are also not considered debris. The product demonstration notes section may cover special items that can be left in the pool after time has expired.
- No demo team member shall enter the water to complete an object recovery. Only arms and hands are allowed into the pool to retrieve an object or to retrieve the vehicle. Companies will be disqualified or penalized depending on the severity of the infraction.
- Communication between demo team members at the pool edge and demo team members piloting the vehicle will be limited. Only tether management issues (e.g. how much tether is out, how much is remaining on the pool deck) can be discussed. Those team members at the pool edge cannot give any directional or product demonstration task information to the pilot. Judges will issue one warning regarding illegal communication. Each future infraction will result in 5 points deducted from the final product demonstration score.
- Communication using cell phones, text messaging, and online social media tools such as Skype, Facebook, Twitter, instant messaging, etc. is NOT permitted during the product demonstration, either between the demo team members at poolside or between any demo team member and anyone outside of the product demonstration station. The ROV and/or the ROV control system is not allowed to broadcast video or other information to anyone outside of the product demonstration area. No exceptions. Companies found broadcasting any data to those outside of the product demonstration area will be disqualified.
- **Product demonstration judges and other competition officials will only communicate with students.** Judges and officials will NOT communicate with mentors, parents, or other non-student members regarding product demonstration information, challenges, or other issues except during pre- and post-competition briefing sessions.

Companies that wish to issue a challenge during the product demonstration run should immediately communicate this challenge to the product demonstration judges. The judges will discuss and

attempt to resolve the issue. If a decision cannot be made, the product demonstration judges will consult with the head judges and competition technical manager to resolve the issue.

### 4.3 DESIGN & SAFETY CONSIDERATIONS

- The competition coordinators and host venues stress the importance of safety practices and procedures to all companies. The score sheets and rubrics will reflect the MATE ROV Competition's efforts to encourage and reward companies that demonstrate exceptional safety practices and procedures.
- **ALL ROVS MUST PASS A SAFETY INSPECTION CONDUCTED BY COMPETITION OFFICIALS PRIOR TO ENTERING THE POOL.** These inspections will be conducted topside to ensure that ROV systems meet the design and building specifications and do not pose a risk to the integrity of the event venue. See [VEHICLE DESIGN & BUILDING SPECIFICATIONS](#) for additional information.
- Radio transmitters that operate on a separate battery are permitted. No batteries are permitted to be in or on the water. No exceptions.

Companies should be aware of all the implications of these wireless devices. There is no assurance that an adjacent company's wireless controller will not interfere with your control systems. Adjacent wireless controllers with a battery that has a higher charge than the nearby controller have demonstrated the ability to "hijack" the nearby control signals. In addition, all wireless controllers are susceptible to external sources of electronic interference. Your system may work fine in your home environment, but not in the industrial environment of the competition. MATE will not stop the clock to resolve wireless control issues. Companies deciding to utilize wireless controllers do so at their own risk.

- Keep an eye out for tripping hazards in the product demonstration station and at your company's work station. Make sure power cords are not laying in pools of water on the deck.
- During your product demonstration, be sure to secure any equipment so that it does not fall off the product demonstration station table, damage the deck, or cause injury.
- Loose fitting clothing, jewelry, and long hair could all become safety issues. Consider securing long shirts or baggy pants, removing jewelry, and tying back long hair when working on or operating your ROV.
- ROVs may be constructed out of materials of your company's choice, provided they meet the design and building specifications and safety regulations. Warning labels should be posted on potentially hazardous components of your ROV system.

- Close toed shoes are required on the pool deck. Safety glasses are required when working on the vehicle.
- Personal flotation devices (PFDs) will not be required at the international competition. No personal flotation devices will be provided by MATE or the host venue. Regional events may require PFDs. Contact [your regional coordinator or visit your regional contest's website](#) to determine if PFDs will be necessary.

## PART 5: ENGINEERING & COMMUNICATION

**NEW IN 2019!!!** MATE is creating an ROV Competition Marketing Kit that includes logos and guidelines for their use. When available, this kit will be posted [here](#).

The ability to effectively communicate information about your vehicle and the design and building process is equally as important as how well your vehicle performs. Strong communication skills are an essential part of good business practices. To emphasize this point, the competition requires the following four engineering and communication components:

- Company spec sheet
- Technical documentation (formerly known as the technical report)
- Engineering presentation (formerly known as the product presentation)
- Marketing display (formerly known as the poster display)

**NOTE: Regional contests may not require all of the Engineering & Communication components.** Contact [your regional coordinator or visit your regional contest's website](#) for more information.

The company spec sheet, technical documentation, and engineering presentation are components where you are communicating with technical audiences, such as potential future clients. (Examples of spec sheets and technical documentation from previous competitions can be found [www.marinetech.org/tech-reports](http://www.marinetech.org/tech-reports). Examples of engineering presentations can be found on [MATE's Vimeo channel](#).) The marketing display should be thought of as part of your marketing (or sales) strategy and aimed at general (including non-technical) audiences.

### TIPS FOR EFFECTIVE WRITTEN AND ORAL COMMUNICATION

Communicating ideas about how to solve a problem and evaluating those ideas against competing alternatives is a critical skill for anyone entering the workplace. It is a skill that is directly linked to decision making about whether or not to hire (or fund) us and our ability to influence the work that we do.

The key to a successful technical documentation and engineering presentation is the way that critical thinking and engineering reasoning are communicated. You can think of the process as technical “storytelling.”

Technical storytelling includes the use of text, images, schematics, and data to effectively communicate the “story” of how your company brainstormed and evaluated ideas to come up with your solution (e.g. ROV, payload tools, and operational strategies) to the problem at hand (product demonstration tasks). It also involves organizing content to efficiently present your work and justify why you did what you did.

However, you should choose details with care. Each detail should help to answer the question "why is what you did the best solution for your company and for this competition?" Describe why a component in the system is critical and how you chose it. Include specifications or dimensions only if they help to explain the “why” and “how” you made choices. Keep in mind that a mechanical drawing with dimensions can replace a lot of text and in many cases do a better job telling details of the story than text.

That said, if something is hard to describe clearly and completely with two to three sentences, consider whether using an image may help. A good technical document balances text and images to provide lots of information concisely, which for a detailed understanding while being quick and easy to read. Remember that your reader is new to your design and needs to understand both what your design is and the process you used to get there. Present text and images in a logical order that helps readers follow your development process and results.

Maintaining a project notebook is a good business practice that will help to capture ideas and document your company’s progress – including your research, designs, trade studies, experiments, data, vehicle specifications, testing, expenditures, and donations. The notebook is also a place to keep track of your company member’s contributions (time, support, etc.).

Along with your notebook, here are some items to consider as you prepare to tell your story:

- What was your company’s "work breakdown structure" (tasks, time, and people)?
- What were the greatest constraints (schedule, budget, equipment, labor, logistics, etc.) on your design process?
- How did the product demonstration tasks and rules influence your design and decisions?
- What systematic process, such as a tradeoff matrix, did you use to evaluate competing design solutions?
- What were the most important design decisions you made and why?
- How did you arrive at your final power budget? What concessions, if any, did you have to make and why?
- How do you calibrate your sensors?

- If your vehicle uses software, where does the code execute? Describe the flow and format of the data.
- Did you have a noteworthy troubleshooting experience? Any problem or procedure that takes more than 20 minutes to figure out is worth understanding and writing down.

**NOTE FOR 2019!!!**

Rather than specifications, this year your company should refer directly to the scoring rubrics posted on the MATE web site under [Missions, Specs, and Scoring](#) for details on what is required for your technical documentation, engineering presentation, and marketing display. The judges will use the rubrics to evaluate and score these engineering and communication components.

## 5.1 COMPANY SPEC SHEET

Your company is required to submit a one-page spec sheet; the specifications for what is required are included below. The goal of the spec sheet is to provide the judges with a “snapshot” of your company. It includes basic information about your company and vehicle.

Company spec sheets will be reviewed by MATE competition coordinators.

Companies will receive up to 20 points for submitting a spec sheet that is one page in length, follows the file size and naming specifications, and contains all of the following information:

### COMPANY SPECS

- **Company and school, club, or community organization name**
- **Home state and/or country**
- **Distance required to travel to the international competition**
- **History of MATE ROV competition participation.** Be sure to specify if your company and/or the members of your company are “new” or “returning.”
- **Company photo and caption indicating members’ names and roles (e.g. CEO, CFO, Design Engineer, Pilot, etc.).** This photo should include all of the members of your company.
- **Range of grade/college levels represented by the members of your company**

### ROV SPECS

- **ROV name** if applicable
- **Total cost.** You must include the approximate cost of any donated items.
- **Size and weight measurements**
- **Total student-hours to design and build.** This should include the number of hours that each and every member of the company worked on the vehicle.
- **Safety features**
- **Special features**
- **Photo of the vehicle**

If all of the above information is included, the specifications for length, size, and naming conventions are followed carefully, and the document is submitted on time, this is an “easy” 20 points!

## 5.2 TECHNICAL DOCUMENTATION

Your company is required to submit technical documentation that will be reviewed and evaluated by a panel of working professionals – individuals who represent science, exploration, government, and industry. (Don’t assume that these same individuals will evaluate your company’s engineering presentation!) The technical documentation is a means for your company to describe the design, operations, and features of your vehicle. Your clients should gain a good technical understanding of your vehicle and your company’s capabilities in addressing your client’s needs for an ROV.

Any changes or additions that you make to your ROV that differ from the information in the technical documentation that you submit should be presented to the judges during your company’s engineering presentation. **NOTE: The judges will not review and rescore revised versions of your technical documentation during the competition.**

Each judge on the panel will award a score (100 points max). Judges’ scores and comments will be returned to you shortly after the event.

**Use the technical documentation scoring rubric posted [here](#) as the guideline for the required components for the technical documentation. This rubric will be posted by March 1, 2019. In the meantime, companies may refer to the previous year’s rubrics posted [here](#) for a general idea of the categories and points.**

## 5.3 ENGINEERING PRESENTATION

During the competition, your company is required to give a 15-minute oral presentation to a panel of working professionals – individuals who represent science, exploration, government, and industry. (Don’t assume that these same individuals will evaluate your company’s technical documentation.) Your presentation should describe the engineering behind your vehicle’s design and operation and address any possible safety issues. It should also highlight any design innovations or creative solutions to solving the product demonstration tasks. After the presentation, the judges will take 10-15 minutes to ask the members of your company questions about your ROV. The judges will evaluate both your presentation and responses to their questions.

**All student members of your company must participate in this presentation and question and answer (Q&A) period.** You are required to have your ROV with you.

**NOTE:** The engineering presentation is designed to be a face-to-face interaction where students and representatives from industry become engaged in conversation. MATE will not provide audio visual

aids, such as slide projectors, computer projection screens, white boards, etc.; however, you are welcome to distribute handouts to help judges better understand the information that you are presenting. **PowerPoint presentations are NOT permitted.** During the Q&A, all members of the company must be present and prepared to answer.

**Instructors, mentors, family members, friends, and members of other companies are permitted to attend.** However, we ask that those in attendance be respectful and courteous throughout the presentation and follow-up question and answer period. Be mindful that this presentation may be a stressful time for the students. If the room becomes crowded or the spectators become distracting, it is up to the judges' discretion to request that some or all spectators leave the presentation. **While they are permitted to attend, instructors and mentors are not allowed to participate.**

Each judge on the panel will award a score (100 points max). Judges' scores and comments will be returned to you shortly after the event.

The judges will pay particular attention to whether or not the vehicle was built by the students from "scratch" or excessively uses complete, off-the-shelf systems. (The [COMPETITION RULES](#) includes more information on this topic). They will also be looking carefully at how the vehicle was designed and built specifically for the product demonstration tasks. Design originality and innovation as well as safeguards to prevent injury or damage to the underwater environment will be noted.

**Use the engineering presentation scoring rubric posted [here](#) as the guideline for the required components for the engineering presentation. This rubric will be posted by March 1, 2019. In the meantime, companies may refer to the previous year's rubrics posted [here](#) for a general idea of the categories and points.**

**Judges may ask questions regarding any of these topics not covered in the presentation as well as other questions about the vehicle, the mission theme, or the company.**

#### **Preparing for your engineering presentation and Q&A**

- Make sure that every member of your company has a good, general working knowledge of your vehicle, even though they may have specialized in one specific aspect of its design and construction.
- Research the specifications of the components that you use in your vehicle. For example, look up the specs of your ROV's camera and be familiar with such numbers as the amount of propulsive force the thrusters produce, the weight of your ROV, etc.
- Make sure that all the members of your company are familiar with your technical documentation. Ask every member to read it over to catch any errors or omissions. This exercise will help to familiarize everyone with all aspects of the project.
- Generally, you will have more to say about your ROV than can be presented in 15 minutes. That is why it is critical to organize your material and practice communicating it. However, avoid



coming across as having memorized your presentation verbatim. Judges want to see that you are prepared and understand the information, not that you can simply regurgitate a rehearsed speech from memory. Ask your instructors or mentors to give you feedback.

**Other important items**

- If during the engineering presentation it becomes apparent that instructors, mentors, and other adults associated with your company exercised more than an advisory role, judges reserve the right to deduct points or, in extreme cases, disqualify companies.

**5.4 MARKETING DISPLAY**

Your company is required to create a display that will be showcased during the competition event. Your display should be an informative, clear, and concise presentation about your company and how you designed and built the specialized tools to effectively complete the product demonstrations. During the competition, your company’s display will be evaluated and scored by a completely different group of working professionals – individuals who will represent science, business, government, industry, and education/outreach.

While some judges will have a technical background, others will have a communications, marketing, or public relations background. In addition, there will be visitors to the competition who may not completely understand what an ROV is or how it is used. Think of these visitors as potential future clients who may authorize funding for your work, but have a limited understanding of the technology (i.e., you need to explain your technology, the tasks at hand, and “sell” them on YOUR products and services). Design your display to communicate to this type of audience.

Each judge will award a score (50 points max). Judges’ scores and comments will be returned to you shortly after the event.

\*\*\*\*\*

**INTERNATIONAL COMPETITION ONLY!**

**NOTE:** The MATE ROV Competition will NOT supply display boards.

**You must provide your own display board. The space that the text and photographs/graphics occupy CANNOT exceed 36” tall by 48” wide. For example, company names CANNOT be mounted above the display board. NO EXCEPTIONS!**

At the international competition, tables will be provided for the displays. Contact [your regional coordinator](#) to see if tables (easels or other) will be provided at your regional event.

MATE will continue to provide scissors, tape, glue sticks, adhesives, and other means of attaching display items to the presentation board, although you are also welcome to bring your own.

\*\*\*\*\*

Use the marketing display scoring rubric posted [here](#) as the guideline for the required components for the marketing display. This rubric will be posted by March 1, 2019. In the meantime, companies may refer to the previous year's rubrics posted [here](#) for a general idea of the categories and points.

**Creating an effective marketing display:**

- Address the theme and make real-world connections.
- Reflect your company's personality and mindset.
- Make key points and be concise.
- Keep the general public in mind.
- Make sure to label any and all figures, graphs, diagrams, and photographs and credit the source.
- Maximize the use of the 36" by 48" display space.
- Make sure that it is both informational and aesthetically pleasing.

**Note:** "Accessories" such as video footage, PowerPoint slide presentations running on laptop computers, video projections, etc. are permitted but should be used with discretion. Remember that the judges will have a limited amount of time to evaluate your marketing display and may find excessive use of audio or video presentations distracting.

However, if you do make a video of your ROV building or competition experience, please submit information about it to the [MATE ROV Competition officials](#) so that it can be shared via MATE's YouTube and Vimeo channels.

## 5.5 CORPORATE RESPONSIBILITY (formerly Outreach and Inspiration)

The MATE ROV Competition uses underwater robotics to inspire and encourage students' interest in STEM (science, technology, engineering, and math) education and careers. Recognizing that the students who participate in MATE competitions are powerful ambassadors for the program as well as effective leaders in raising awareness of important issues and bringing about positive change, companies have the opportunity to earn up to 10 points for "corporate responsibility."

Corporate responsibility includes, but is not limited to, the following:

- **Mentoring** consists of, for example, providing guidance to other students in your area who are designing and building an ROV for the competition or a science or other project.
- **Engaging the community** includes demonstrating your ROV and sharing information about your company at festivities and other community-wide events. Presenting to a Rotary Club or your school districts board of directors are other examples.
- **Media outreach** consists of:
  - o Developing a list local media contacts
  - o Writing a press release about your participation in the MATE ROV competition
  - o Distributing it to your media contacts
  - o Following up with your media contacts to see if they're interested in your company and its ROV

- Compiling a summary of results

Here are some [general guidelines](#) for working with the media. They are specific to the international competition, but can be easily modified for regional events.

- **Raising awareness of societal (including environmental) ) issues** includes, for example, ensuring access to clean water around the globe and monitoring water quality and restoring fish habitat, as is featured within Task 2: Maintaining Healthy Waterways.
- Corporate responsibility efforts will be reviewed by competition coordinators and awarded 0 to 10 bonus points, depending on the number and scope of the outreach and awareness activity(s), i.e., the number of other students or members of the community engaged, the number of mentoring sessions, etc.

Make sure to include the following information in your write-up:

- Type of activity (e.g. mentoring, exhibiting at a community event, raising awareness)
- Locations, dates, and the amount of time spent on the activity
- Number of students or community members (if a large event, this can be an approximate) involved
- Description of your actions, outcomes, and other information that helps to demonstrate the quality of your time and efforts
- For media outreach, please submit a copy of your press release, a copy of your media contacts list, and a summary of news articles, TV or radio coverage, etc. that your company received. Include copies of articles and URLs, and list any television or radio coverage. Be sure to include name of outlet, date, and a summary of the coverage.

## PART 6: SUBMISSION GUIDELINES AND KEY DEADLINES

### 6.1 Documentation

Companies advancing to the international competition are required to submit technical documentation, a company spec sheet, a SID, a fluid power diagram (if fluid power is used), a micro-ROV design document, a micro-ROV SID, and a company safety review. In addition, companies may submit a JSA, image recognition software documentation, and documents supporting their corporate responsibility efforts.

**Regional competitions may not require all documentation.** Contact [your regional coordinator or visit your regional contest's website](#) to determine what documentation must be submitted for your regional and the date it is due.

DOC-006: All required documentation sent to the MATE ROV Competition officials MUST be in searchable PDF format (see <https://fd4686477cb19f983f54->

[68abf00cbc1a2cc111562c013cb867db.ssl.cf1.rackcdn.com/SearchablePDFs.pdf](https://68abf00cbc1a2cc111562c013cb867db.ssl.cf1.rackcdn.com/SearchablePDFs.pdf) for information about creating searchable PDFs.

DOC-007: The technical documentation may be up to 8 MB in size, the other documents are restricted to a maximum file size of 2MB.

DOC-008: All documents should use the following naming convention: School or organization name\_company name\_DOCUMENT TYPE\_2019.pdf, where DOCUMENT TYPE is technical documentation, spec sheet, SID [type – electrical or fluid], micro-ROV design, company safety review, or JSA. They must be submitted via the form located here – <https://www.emailmeform.com/builder/form/cU50v6e90Xd2G6FEOaec8P>

**Submit only your final documents and use only ONE form** (multiple files can be attached to one emailmeform). Revised documents submitted at a later date and/or multiple forms will not be accepted. The MATE competition will use the date-stamp on your form to determine your initial submission.

### **NEW IN 2019!!!**

Upon submitting your documentation, you will receive a confirmation email noting all of the documents that were successfully uploaded and submitted. **Check this notification carefully to verify that all of your documents were properly uploaded and submitted!** If there was an error while submitting your documents, contact the MATE ROV Competition and upload **ALL** documents again.

DOC-009: For the international competition, due date for the required documentation and the JSAs is 11:59 PM, Hawaii Time Zone, on May 23, 2019.

DOC-010: Companies will lose points on their initial safety and documentation review if documents:

- 4) Are submitted late
- 5) Exceed the size limit
- 6) Use improper naming conventions
- 7) Are not submitted on ONE form

### *6.1.1 Corporate Responsibility Documentation*

DOC-011: Corporate responsibility efforts should be submitted to: –

<https://www.emailmeform.com/builder/form/D6bW4p353aY>

DOC-012: The following naming convention should be used for corporate responsibility documentation: School or organization name\_company name\_Corporate Responsibility ##\_2019, where ## is the number of the document uploaded. You can upload a variety of file types (pdfs, jpegs, etc.) and multiple files, but the size of each file should not exceed 2MB. Number each file to distinguish between them.

**Submit only your final corporate responsibility documents and use only ONE form** (multiple files can be attached to one email form). Revised documents submitted at a later date and/or multiple forms will not be accepted. The MATE competition will use the date-stamp on your form to determine your initial submission.

DOC-013: For the international competition, due date for the corporate responsibility documentation is 11:59 PM, Hawaii Time Zone, on June 6<sup>th</sup>, 2019.

NOTE: By submitting your documentation, you are giving the MATE ROV Competition permission to publish these documents on its web site.

### *6.1.2 Image Recognition Documentation*

DOC-011: Image Recognition: Companies choosing to use image recognition software to identify the benthic species are required to submit information about their image recognition software to MATE ROV Competition officials. This document should detail how the company created their image recognition software and include the following items:

On one page:

- Algorithm description: A detailed description of the inputs to the vision processing and a detailed description of the output of the vision processing. A description of the algorithm should also be included, describing the method (shape recognition, line recognition, etc.) used by the company to complete the task.
- Data flow diagram: A diagram showing the flow of data from the camera on the ROV to the output that identifies the benthic species.

Additional information includes:

- A library of code files: A document of all the code used including header files, libraries, and a README describing each file.

An example of an acceptable image recognition document can be found here:

[https://www.marinetech.org/files/marine/files/ROV%20Competition/2019%20competition/Missions/Explorer\\_E05\\_China\\_Nanjing%20Institute%20of%20Technology\\_IR\\_909.pdf](https://www.marinetech.org/files/marine/files/ROV%20Competition/2019%20competition/Missions/Explorer_E05_China_Nanjing%20Institute%20of%20Technology_IR_909.pdf)

Shape Overlay Resources:

C, C++, Java, Python, Cuda, Android, iOS: <https://opencv.org/>

Arduino: <https://www.open-electronics.org/a-video-overlay-shield-for-arduino/>

Matlab: <https://www.mathworks.com/help/vision/ref/insertshape.html>

Companies may choose to use other image processing algorithms as needed.

DOC-012: All documents should use the following naming convention: School or organization name\_company name\_DOCUMENT TYPE\_2019.pdf, where DOCUMENT TYPE is data flow diagram, algorithm description, code file # (multiple code files can be uploaded). For companies advancing to the international competition, files must be submitted via the form located here – <https://www.emailmeform.com/builder/form/cU50v6e90Xd2G6FE0aec8P>

**Submit only your final image recognition documents and use only ONE form** (multiple files can be attached to one emailmeform). This form should be submitted separately from emailmeform for technical documentation.

Regionals may or may not require submission of image recognition documentation. Contact [your regional coordinator or visit your regional contest's website](#) to determine what documentation must be submitted for your regional and the date it is due.

Image recognition documentation will be evaluated by MATE competition officials. Any potential issues or concerns will be discussed with the company until a resolution is found. Companies that do not submit image recognition documentation or do not resolve issues with the MATE ROV Competition judges will not be permitted to use image recognition software to complete the benthic species identification step of Task 2: Maintaining Healthy Waterways.

DOC-013: For the international competition, due date for the image recognition documentation is 11:59 PM, Hawaii Time Zone, on May 23<sup>rd</sup>, 2019.

## 6.2 KEY DEADLINES

Below is a summary of key dates and deadlines for the 2019 MATE competition season. **Note that regional competitions will have their own set of key dates and deadlines.** Contact [your regional coordinator or visit your regional contest's website](#) for more information.

- December 1, 2018: Registration opens (note that individual regional registrations will open as regionals secure their location and date)
- April 1, 2019: Last day to submit laser specifications and hydraulic fluid information. Companies with regional competitions near April 1<sup>st</sup> should submit specifications early to allow at least 1 week for approval.
- April 1, 2019: Last day to register for the fluid power quiz. Note: No fluid power quizzes will be issued between March 10<sup>th</sup> and March 26<sup>th</sup>. It may take five working days for your fluid power quiz to be issued after purchase. Companies should plan accordingly.
- May 12, 2019: [Video demonstration](#) submission deadline for teams prohibitively far from a MATE regional.

- May 23, 2019: Submission deadline for:
  - Technical documentation
  - Company spec sheet
  - SIDs (including electrical, fluid, Non-ROV Device)
  - Micro-ROV design document
  - Company safety review
  - Job site safety analysis (optional)
  - Image recognition (optional)
- June 6, 2019: Submission deadline
  - Corporate responsibility documentation